



DUAL BAND Mobile SGH-A200

by Toko (www.gsm-free.com)

SERVICE Manual

DUAL BAND MOBILE CELLULAR PHONE

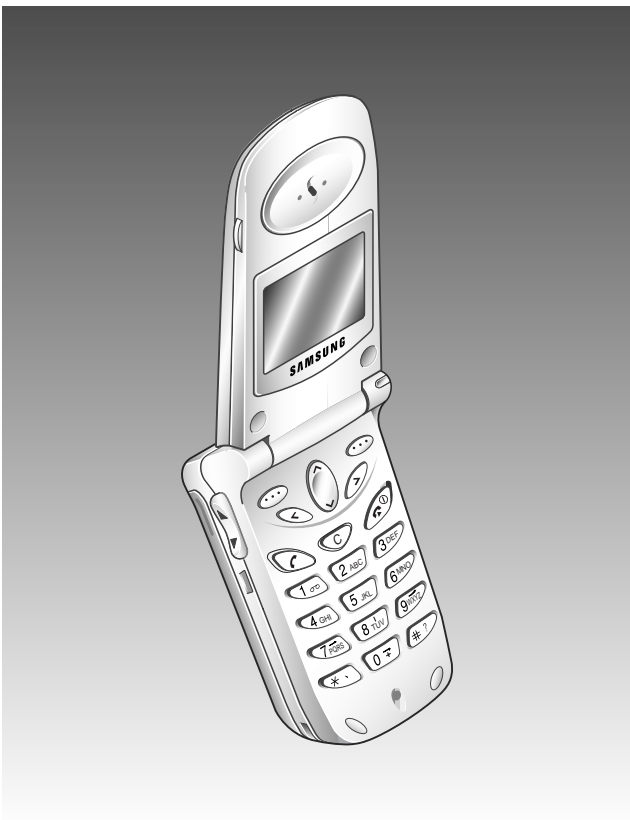

CONTENTS

1. Exploded Views and Parts List
2. PCB Diagrams
3. Electrical Parts List
4. Block Diagrams
5. Flow Chart of Troubleshooting and Circuit Diagram

1. Exploded Views and Parts List

- 1-1 Main
- 1-2 Main Parts List
- 1-3 Travel Adapter
- 1-4 Travel Adapter Parts List
- 1-5 Ciger Light Adapter
- 1-6 Ciger Light Adapter Parts List
- 1-7 Test Jig
- 1-8 Wearable EAR Microphone
- 1-9 Data Kit
- 1-10 Battery Charger

2. PCB Diagrams

- 2-1 Main Top
 - 2-1-1 Main RF Top
 - 2-1-2 Main Base Band Top
- 2-2 Main Bottom
 - 2-2-1 Main RF Bottom
 - 2-2-2 Main Base Band Bottom

3. Electrical Parts List

- 3-1 Main Parts List Top
- 3-2 Main Parts List Bottom

4. Block Diagrams

- 4-1 Main Base Band
- 4-2 Main RF
 - 4-2-1 RF Tx Part
 - 4-2-2 RF Rx Part

5. Flow chart of Troubleshooting and Circuit Diagram

- 5-1 Power ON
 - 5-2 Initial
 - 5-3 Charging Part
 - 5-4 Sim Part
 - 5-5 Microphone Part
 - 5-6 Speaker Part
 - 5-7 Key Data Input
 - 5-8 Alert tone
 - 5-9 Ring Indicator
 - 5-10 Back Light
 - 5-11 GSM Receiver
 - 5-12 GSM Transmit
 - 5-13 DCS Receiver
 - 5-14 DCS Transmit
-

1. Exploded Views and Parts List

1-1 Main

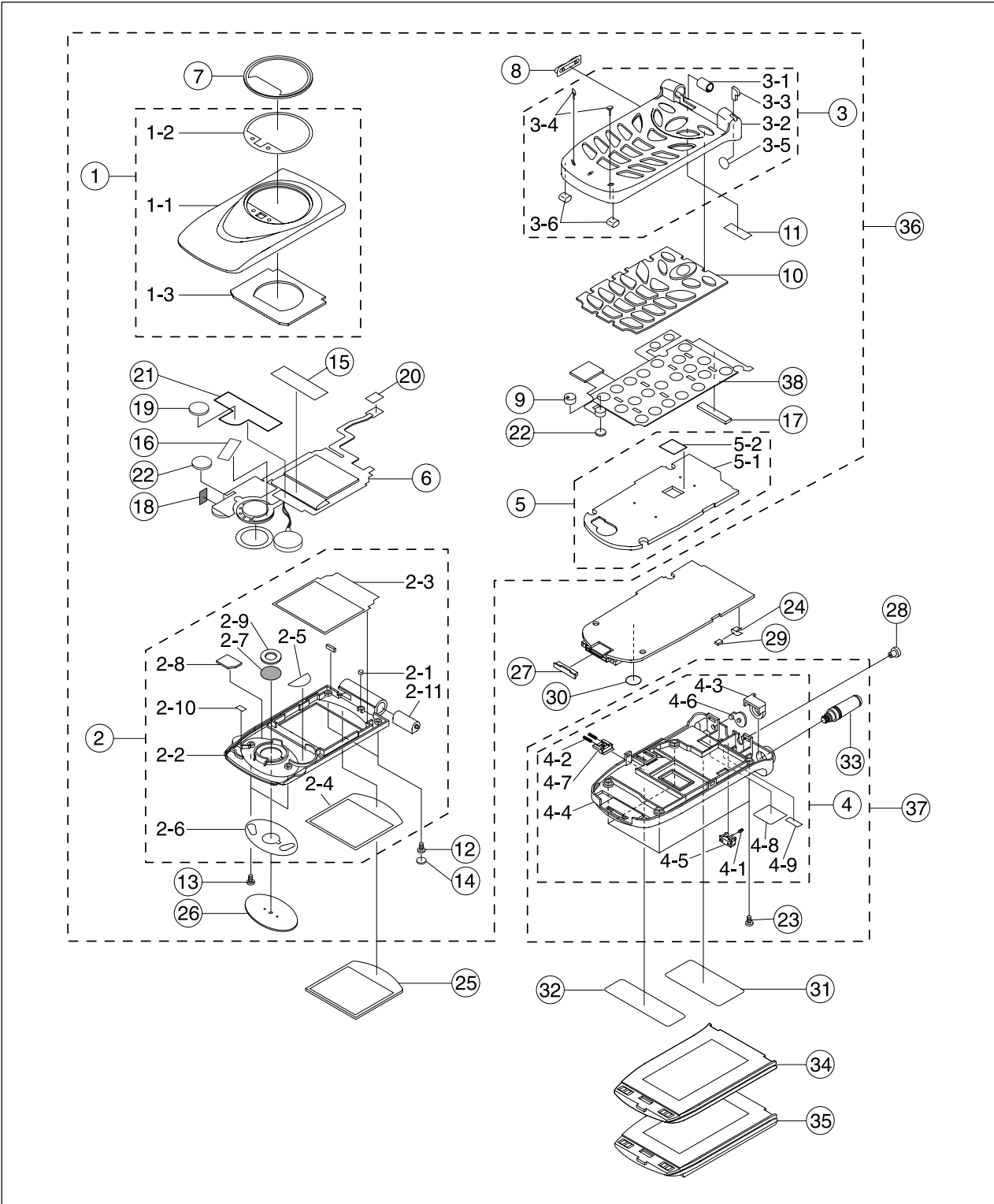

1-2 Main Parts List

NO	SEC CODE	DESCRIPTION	COLOR	SVC	Q`TY	REMARKS	
1		GH75-00925A	MEC-FOLDER UPPER	WHITE	SA	1	
		GH75-00970A	MEC-FOLDER UPPER	WHITE	SA	1	SGH-A200
	1-1	GH72-02098A	PMO-FOLDER UPPER		SNA	1	
		GH72-02174A	PMO-FOLDER UPPER		SNA	1	SGH-A200
	1-2	GH74-00307A	MPR-TAPE WATCH WINDOW		SNA	1	
	1-3	GH74-01114A	MPR-SPONGE WATCH LCD		SNA	1	
2		GH75-00926A	MEC-FOLDER LOWER	WHITE	SA	1	
	2-1	GH70-00039A	ICT-MAGNETIC		SNA	1	
	2-2	GH72-02099A	PMO-FOLDER LOWER		SNA	1	
	2-3	GH74-00309A	MPR-SPONGE MAIN LCD		SNA	1	
	2-4	GH74-00310A	MPR-TAPE MAIN LCD		SNA	1	
	2-5	GH74-00311A	MPR-TAPE VIBRATOR		SNA	1	
	2-6	GH74-00312A	MPR-TAPE SPEAKER COVER		SNA	1	
	2-7	GH74-00580A	MPR-EMI MESH SPEAKER		SNA	1	
	2-8	GH74-00721A	MPR-SPONGE COIL		SNA	1	
	2-9	GH74-01240A	MPR-SPONGE SPEAKER		SNA	1	
	2-10	GH74-01241A	MPR-TAPE BUZZER		SNA	1	
	2-11	GH75-00928A	MEC-HINGE		SA	1	
	3		GH75-00924A	MEC-FRONT COVER	WHITE	SA	1
3-1		GH72-00636A	PMO-HINGE DUMMY		SNA	1	
3-2		GH72-02097A	PMO-FRONT COVER		SNA	1	
3-3		GH72-02394A	PMO-REFLECTOR LED		SNA	1	
3-4		GH73-00266B	RMO-DAMPER(L)		SNA	2	
3-5		GH74-00445A	MPR-SPONGE CMIC		SNA	1	
3-6		GH74-01296A	MPR-SHIELD FOAM		SNA	2	
4		GH75-00927A	MEC-REAR COVER	WHITE	SA	1	
	4-1	GH61-00008A	SPRING-LOCKER		SNA	1	
	4-2	GH61-00011A	SPRING-SIM LOCKER		SNA	2	
	4-3	GH71-00380A	NPR-BRACKET ANT		SNA	1	
	4-4	GH72-02102A	PMO-REAR COVER	WHITE	SNA	1	
	4-5	GH72-02103A	PMO-LOCKER BATT	WHITE	SNA	1	
	4-6	GH72-02104A	PMO-EAR JACK COVER	LIGHT/GRAY	SNA	1	
	4-7	GH72-02330A	PMO-SIM KNOB	WHITE	SNA	1	
	4-8	GH74-01236A	MPR-TAPE EARPHONE	WHITE	SNA	1	
	4-9	GH74-01237A	MPR-TAPE MOBILE	WHITE	SNA	1	
5		GH75-01022A	MEC-SHIELD COVER		SA	1	
	5-1	GH72-02101A	PMO-SHIELD COVER		SNA	1	
	5-2	GH74-01238A	MCT-SHIELD GASKET		SNA	1	
6		GH07-00051A	LCD-SGHA288		SA	1	
7		GH72-00640A	PMO-WATCH WINDOW		SA	1	
		GH72-00640D	PMO-WATCH WINDOW SAMSUNG		SA	1	SGH-A200
8		GH72-00940A	PMO-KNOB VOLUME		SA	1	
9		GH73-00504A	RMO-HOLDER MIC		SA	1	
10		GH73-00580A	RMO-KEY PAD		SA	1	
		GH73-00580A	RMO-KEY PAD		SA	1	SGH-A200
11		GH74-00587A	MPR-DUMMY SHEET		SA	1	
12		6001-000464	SCREW-MACHINE		SA	2	PH,+,M1.4,L4,BLK
13		6001-001402	SCREW-MACHINE		SA	2	PH,+,M1.4,L3,WHT

NO	SEC CODE	DESCRIPTION	COLOR	SVC	Q`TY	REMARKS	
14		GH74-00611B	MPR-SCREW CAP	WHITE	SA	2	
15		GH74-00770A	MPR-ESD SHEET		SA	1	
16		GH74-00979A	MPR-SHEET SPEAKER		SA	1	
17		GH74-01254A	MPR-SPONGE EARJACK		SA	1	
18		GH74-01294A	MPR-CLOTH BUZZER		SA	1	
19		GH74-01295A	MPR-SPONGE VIB SPEAKER		SA	1	
20		GH74-01297A	MPR-SHIELD FOAM CONN		SA	1	
21		GH74-01332A	MPR-GASKET LOWER		SA	1	
22		GH74-40518A	MCT-BACKUP TAPE		SA	2	
23		6001-000464	SCREW-MACHINE		SA	4	
24		GH71-00095A	NPR-CONTACT ANT		SA	1	
25		GH72-00602A	PCT-WINDOW LCD		SA	1	
26		GH72-00647B	PMO-SPEAKER COVER		SA	1	
27		GH73-00578A	RMO-CONNECTOR COVER		SA	4	
28		GH73-00579A	RMO-MOBILE CAP		SA	1	
29		GH73-00667A	RMO-ANT.CONTACT RUBBER		SA	1	
30		GH74-40518A	MCT-BACKUP TAPE		SA	1	
31		GH68-01684A	LABEL(R)-MAIN(CHNA)		SNA	1	
		GH68-01952A	LABEL(R)-MAIN(XSP)		SNA	1	SGH-A200
32		GH68-01685A	LABEL(R)-MAIN(A288)		SNA	1	
33		GH42-00076B	ANTENNA-SGHA288		SA	1	
34		GH43-00283A	BATTERY-SLIM-SGHA288		SA	1	
		GH43-00326A	BATTERY-SLIM-SGHA200		SA	1	SGH-A200
35		GH43-00305A	BATTERY-STD-SGHA288		SA	1	
		GH43-00327A	BATTERY-STD-SGHA200		SA	1	SGH-A200
36		GH97-01829A	MEA FRONT-TOTAL(WHT)		SNA	1	
		GH97-01924A	MEA FRONT-COVER(WHT)		SNA	1	SGH-A200
37		GH97-01830A	MEA REAR-TOTAL(WHT)		SNA	1	
38		GH59-00181A	UNIT-SGH-A288 KEY PAD		SA	1	

SGH-A288 COLOR & CODE

ITEM \ COLOR	WHITE PEARL	GOLD	SILVER
MEC-FOLDER UPPER	GH75-00925A	GH75-00925B	GH75-00925C
MEC-FOLDER LOWER	GH75-00926A	GH75-00926B	GH75-00926C
MEC-FRONT COVER	GH75-00924A	GH75-00924B	GH75-00924C
MEC-REAR COVER	GH75-00927A	GH75-00927B	GH75-00927C
MPR-SCREW CAP	GH74-00611B	GH74-00313H	GH74-00313F
PMO-SPEAKER COVER	GH72-00647B	GH72-00647J	GH72-00647K
ANTENNA-SGHA288	GH42-00076B	GH42-00076B	GH42-00076B
BATTERY-SLIM-SGHA288	GH43-00283A	GH43-00283C	GH43-00283B
BATTERY-STD-SGHA288	GH43-00305A	GH43-00305C	GH43-00305B

SGH-A200 COLOR & CODE

ITEM \ COLOR	WHITE PEARL	GOLD	SILVER
MEC-FOLDER UPPER	GH75-00970A	GH75-00970B	GH75-00970C
MEC-FOLDER LOWER	GH75-00926A	GH75-00926B	GH75-00926C
MEC-FRONT COVER	GH75-00924A	GH75-00924B	GH75-00924C
MEC-REAR COVER	GH75-00927A	GH75-00927B	GH75-00927C
MPR-SCREW CAP	GH74-00611B	GH74-00313H	GH74-00313F
PMO-SPEAKER COVER	GH72-00647B	GH72-00647J	GH72-00647K
ANTENNA-SGHA288	GH42-00076B	GH42-00076B	GH42-00076B
BATTERY-SLIM-SGHA200	GH43-00326A	GH43-00326C	GH43-00326B
BATTERY-STD-SGHA200	GH43-00327A	GH43-00327C	GH43-00327B

1-3 Travel Adapter

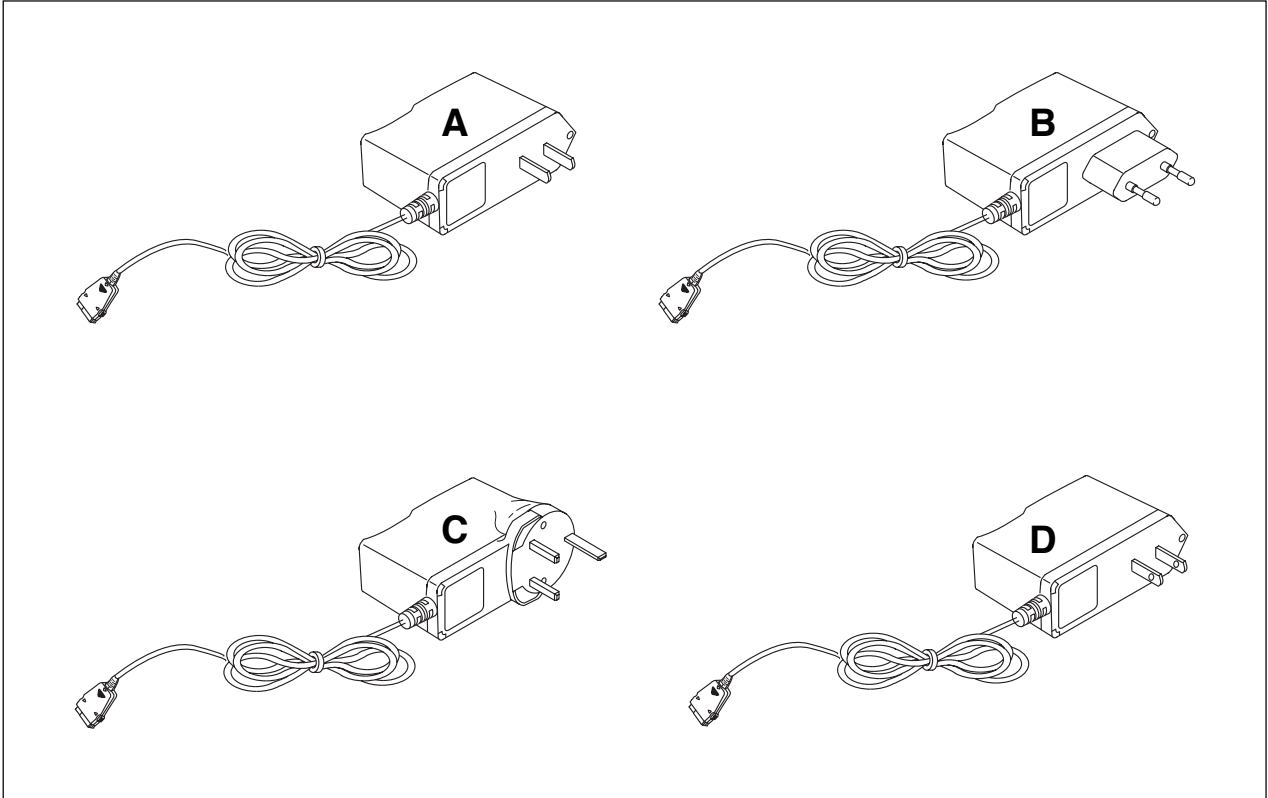

1-4 Travel Adapter Parts List

TYPE	SEC CODE	REMARK
A	GH44-00171A	CHINA
B	GH44-00184A	EUROPE
C	GH44-00171C	UNITED KINGDOM
D	Gh44-00171E	TAIWAN

1-5 Ciger Light Adapter

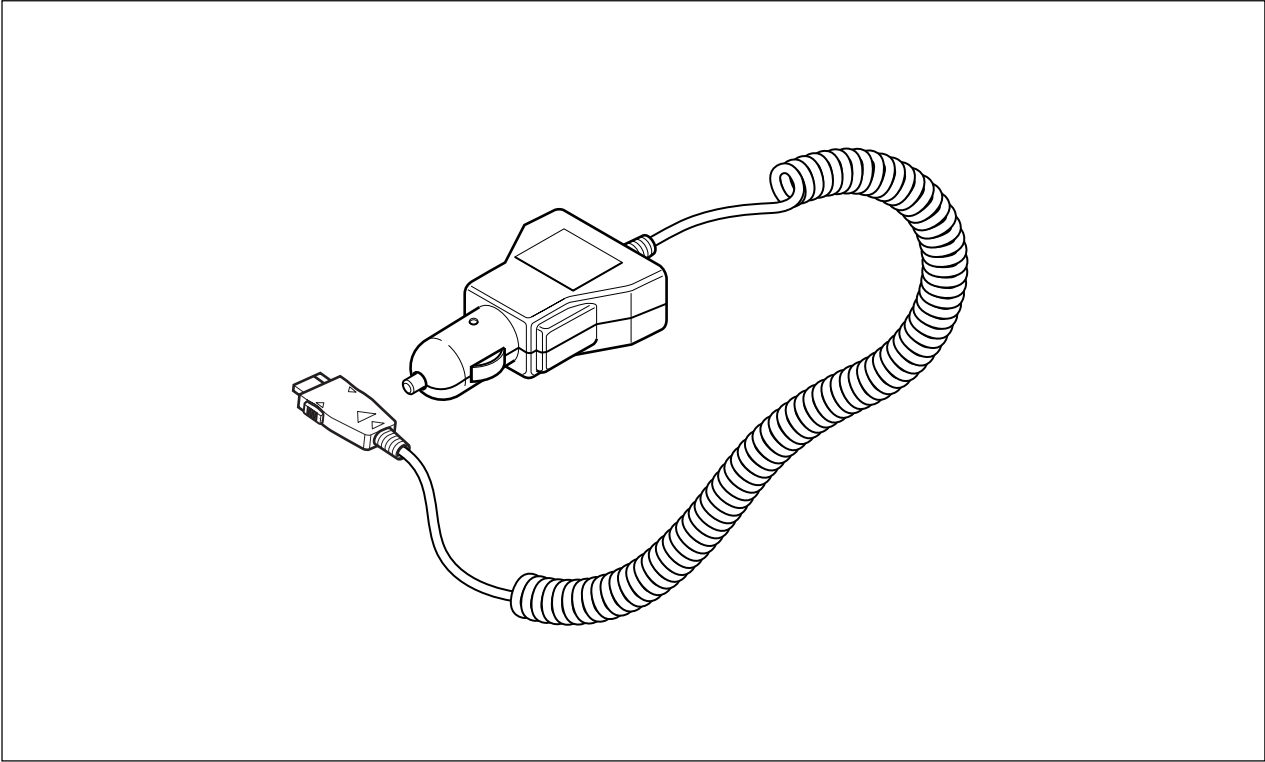

1-6 Ciger Light Adapter Parts List

DESCRIPTION	SEC CODE	REMARK
Ciger Light Adapter Code	GH44-00170A	BLACK

1-7 Test Jig

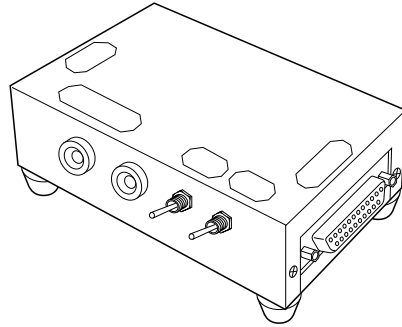

TEST JIG

GH80-10508A

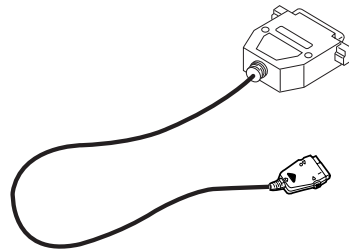

TEST JIG CABLE

GH39-00079A

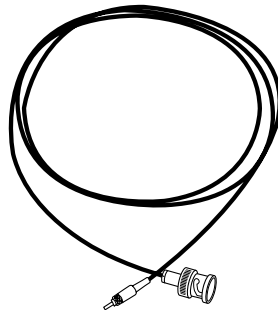

RF JIG CABLE

GH39-00093A

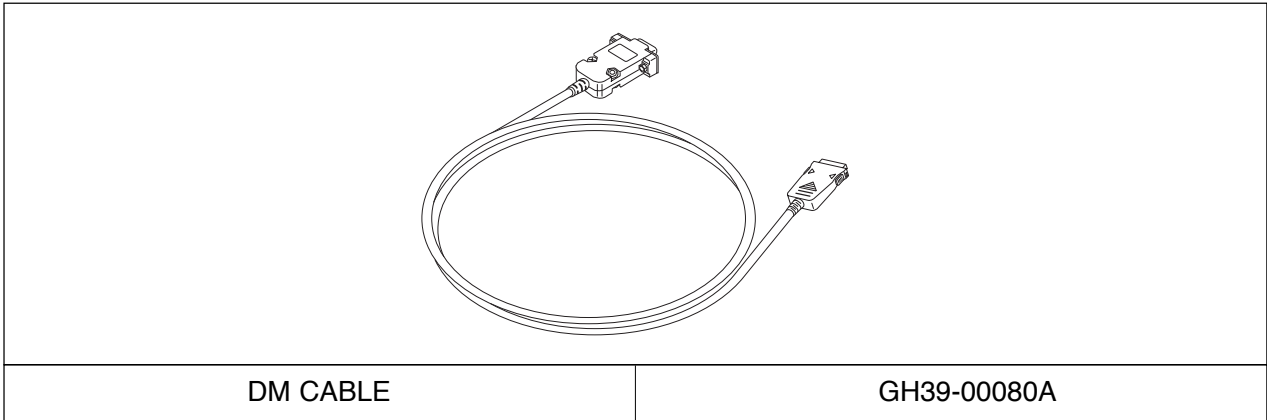

1-7-1 Test Jig

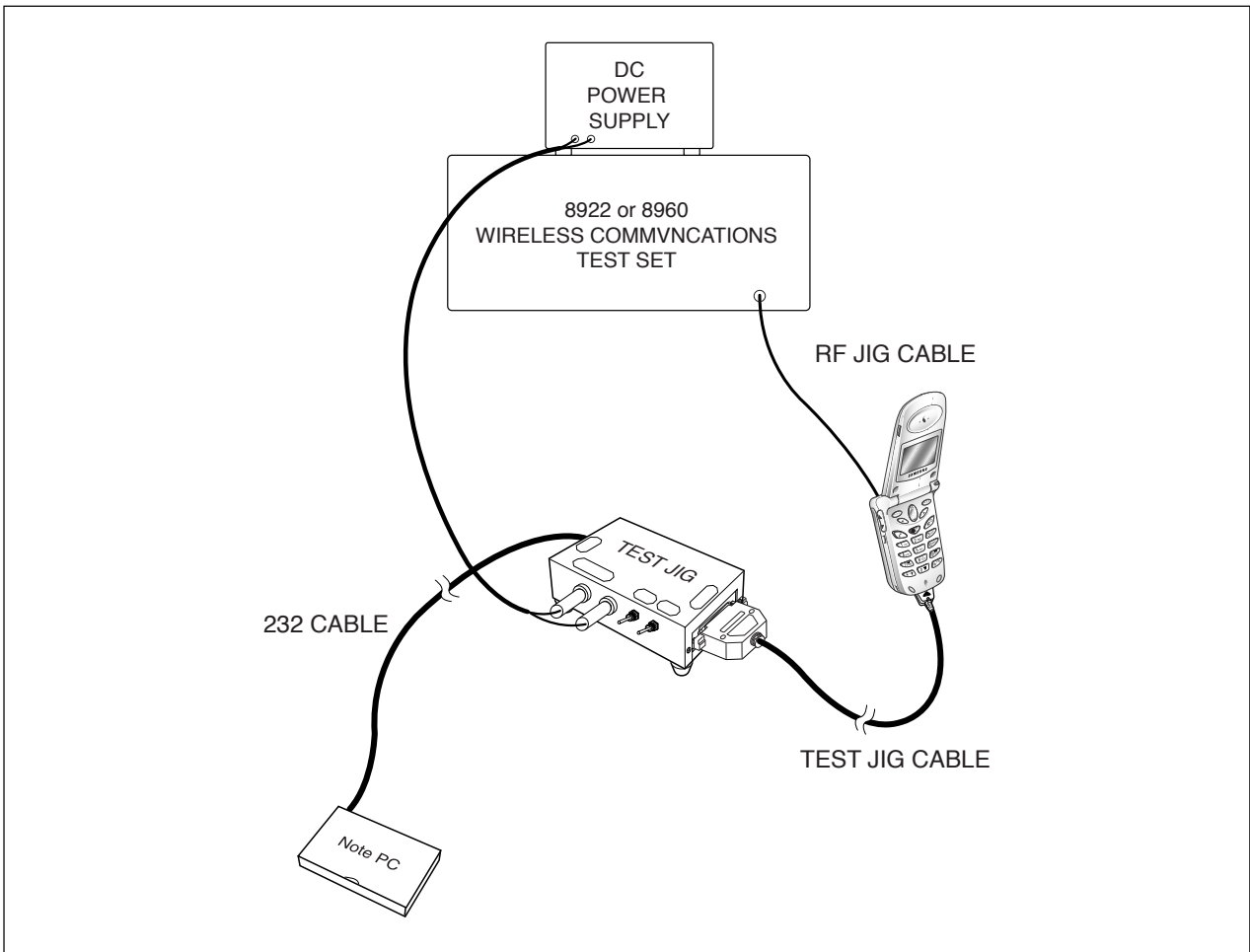

1-8 Wearable EAR Microphone

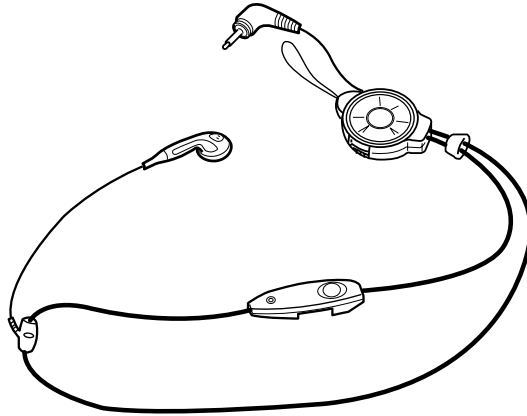

DESCRIPTION	SEC CODE	REMARK
Wearable EAR Microphone	GH59-00168A	SGH-A288
	GH59-00168B	SGH-A200

1-9 Data Kit

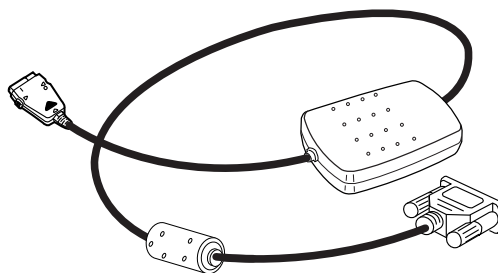

DATA KIT	GH39-00078A
----------	-------------

1-10 Battery Charger

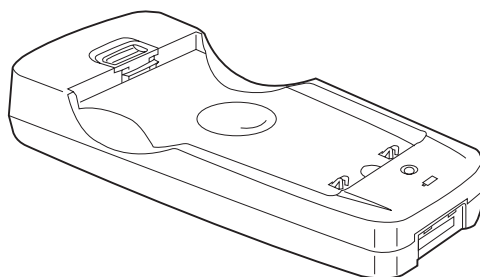

DESCRIPTION	SEC CODE	REMARK
BATTERY CHAGER	GH44-00177A	SGH-A288
	GH44-00177C	SGH-A200

2. PCB Diagrams

2-1 Main Top

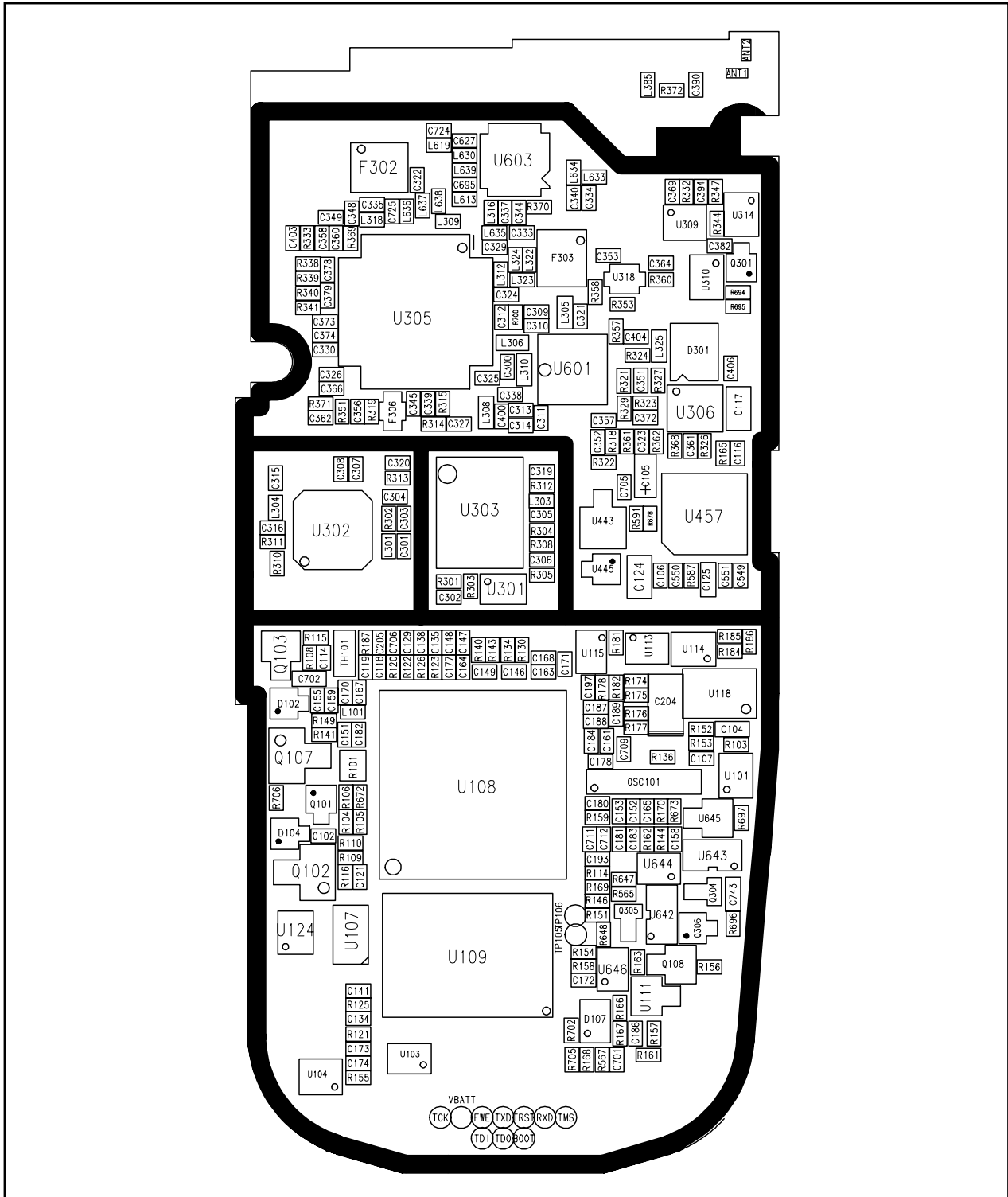

2-1-1 Main RF Top

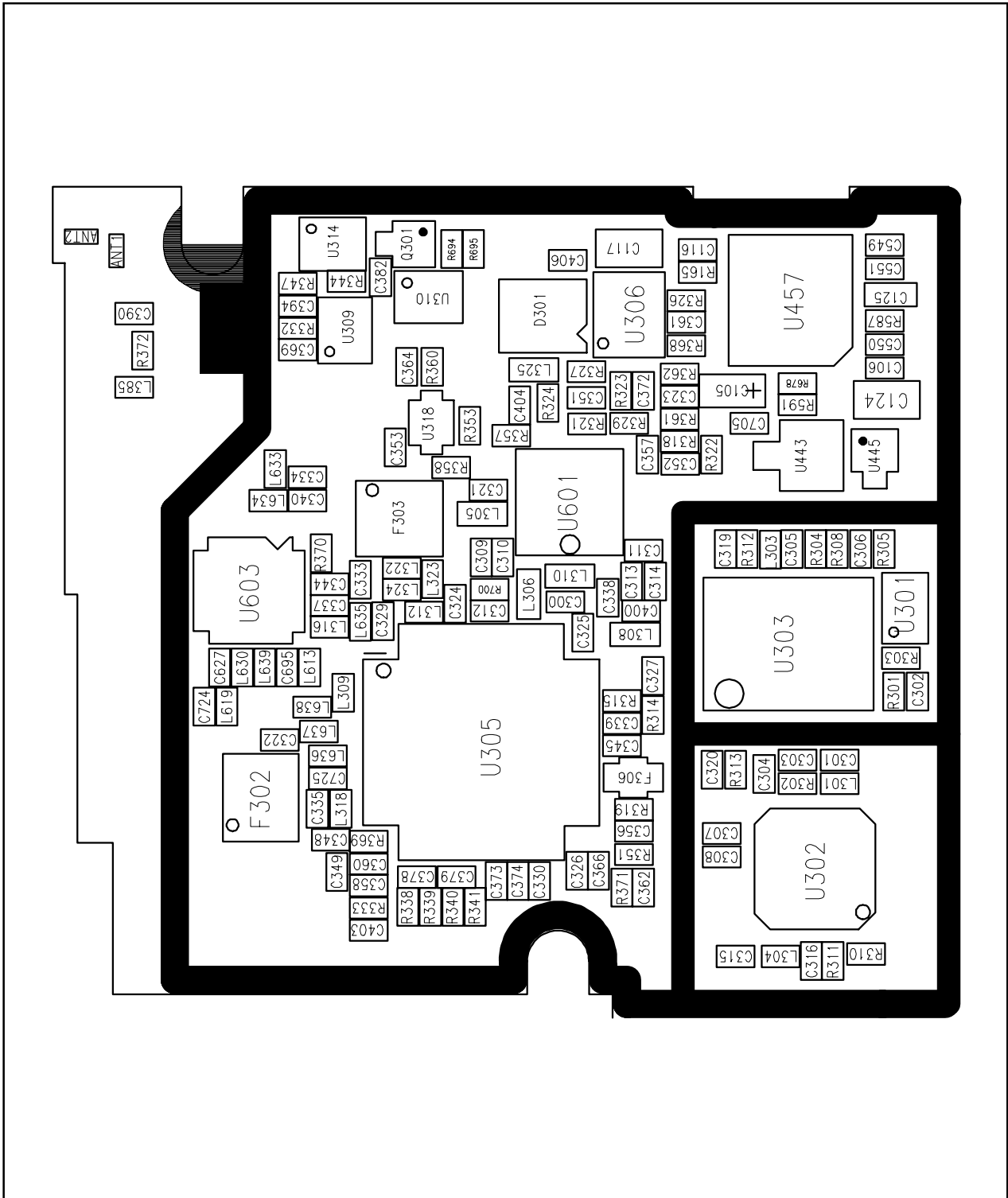

2-2 Main Bottom

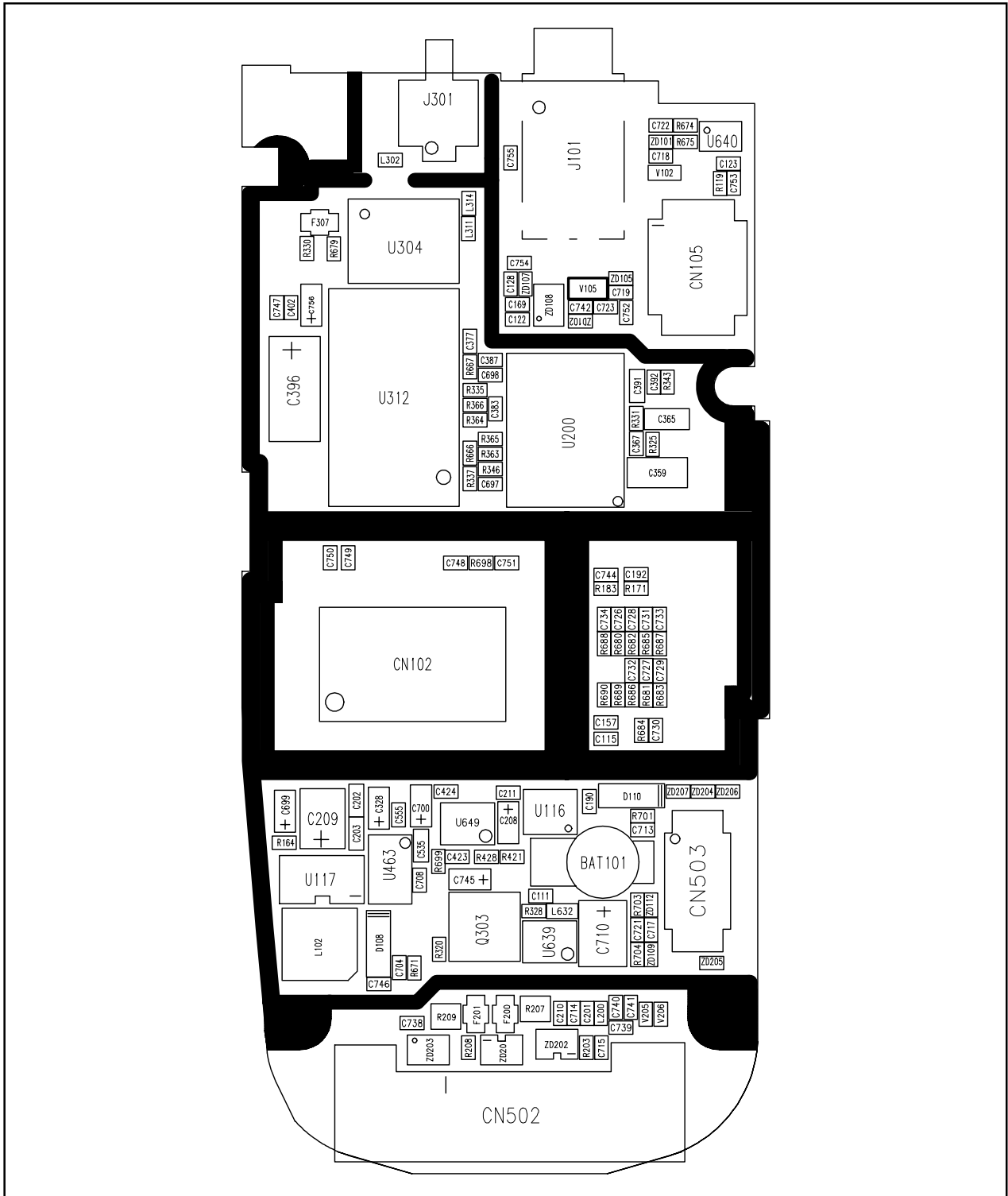

2-2-1 Main RF Bottom

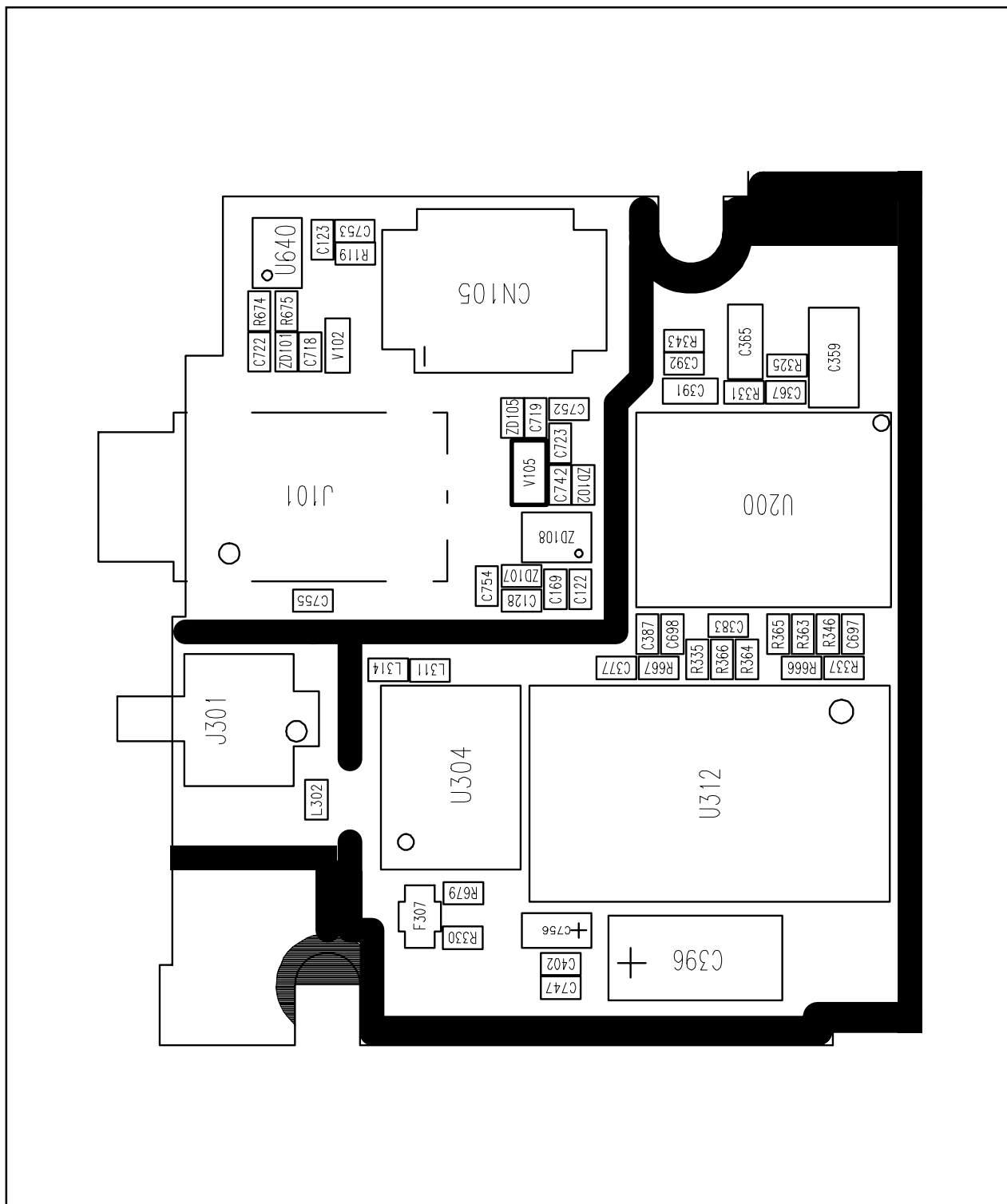

2-2-2 Main Base Band Bottom

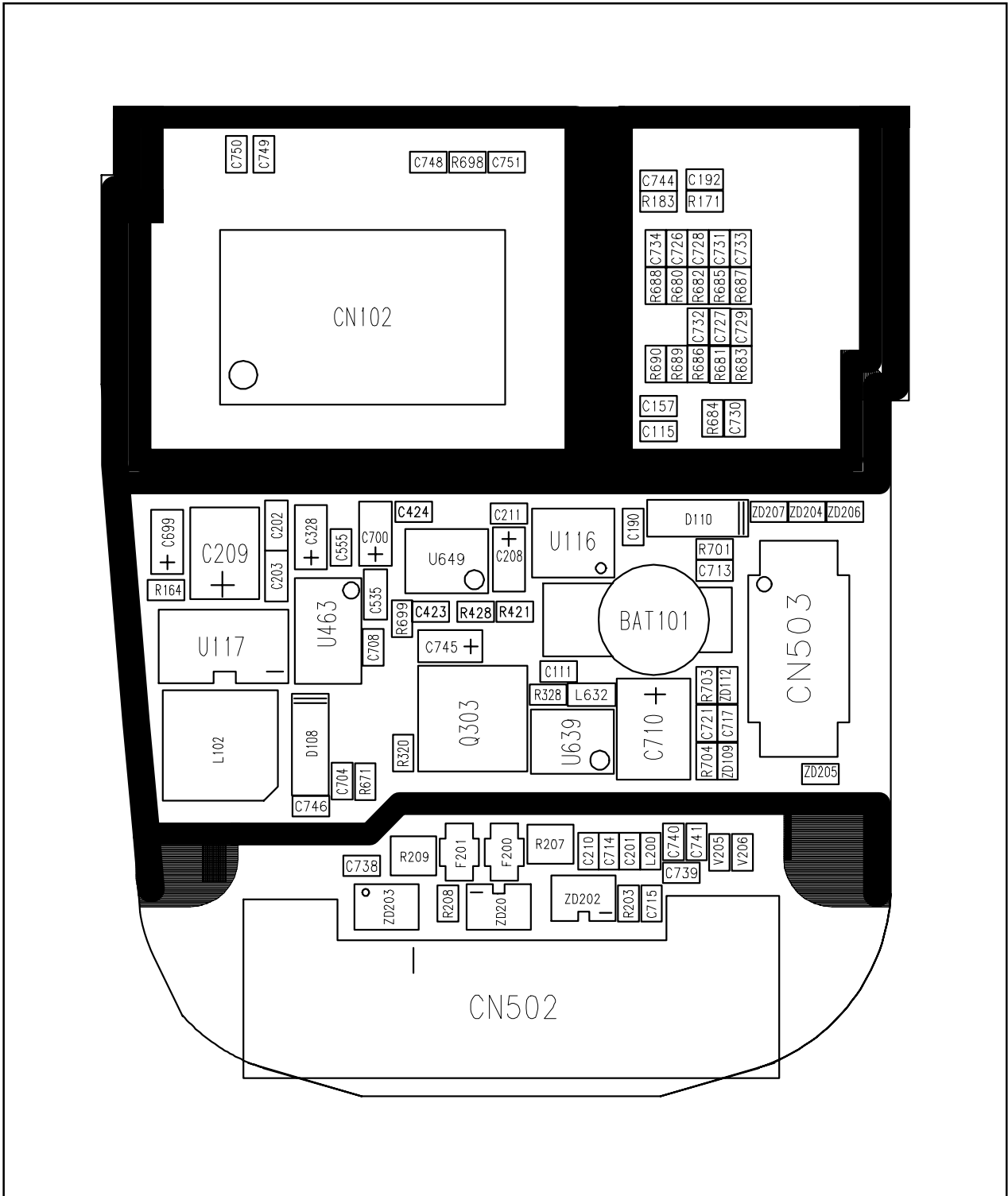

3. Electrical Parts List

3-1 Main Parts List Top

	SEC CODE	Reference	Part Description	Vendor Part No.
1	D301	0404-001054	TR-SMALL SIGNAL;HSMS-2805-L31	HSMS-2805-L31
2	D102,D104	0407-001002	TR-SMALL SIGNAL;DAN222TL	DAN222TL
3	D107	0407-001007	TR-SMALL SIGNAL;UMN1	UMN1
4	Q108	0501-000162	TR-SMALL SIGNAL;2SA1576FRT106	2SA1576FRT106
5	Q103	0501-000218	TR-SMALL SIGNAL;2SC4081BRT106	2SC4081BRT106
6	Q102,Q107	0501-002011	TR-SMALL SIGNAL;2SD2114KT146V	2SD2114KT146V
7	U111	0501-002202	TR-SMALL SIGNAL;MMBT2222AWT1	MMBT2222AWT1
8	U445	0504-000167	TR-SMALL SIGNAL;DTC114EE/TR	DTC114EE/TR
9	Q304,Q305	0504-000168	TR-SMALL SIGNAL;DTC144EE/TR	DTC144EE/TR
10	Q101,Q301	0504-001012	TR-SMALL SIGNAL;DTC114YE	DTC114YE
11	Q306	0504-001016	TR-SMALL SIGNAL;DTA114EE-TL	DTA114EE-TL
12	U443	0504-001021	TR-SMALL SIGNAL;DTB113ZK	DTB113ZK
13	U104,U124	0504-001042	TR-SMALL SIGNAL;BCR10PN	BCR10PN
14	U309,U314	0504-001058	TR-SMALL SIGNAL;BCR08PN	BCR08PN
15	U114	0505-001332	TR-SMALL SIGNAL;FDG6301N	FDG6301N
16	U101,U310	0505-001423	TR-SMALL SIGNAL;FDG6323L	FDG6323L
17	U301	0506-000151	LED;UMZ1N-TR	UMZ1N-TR
18	U644	0801-000794	IC;TC7S08FUTE85L	TC7S08FUTE85L
19	U646	0801-002345	IC;TC7S04FU(TE85L)	TC7S04FU(TE85L)
20	U642,U643	0801-002510	IC;TC7W74FK(TE85L)	TC7W74FK(TE85L)
21	U103	0801-002540	IC;NC7SZ19P6X	NC7SZ19P6X
22	U113,U115	1001-001145	IC;MAX4599EXT-T	NC7SZ19P6X
23	U109	1106-001301	IC;LRS1337	LRS1337
24	U306	1201-001018	IC;LM7131ACM5	LM7131ACM5
25	U118	1202-001022	IC;TC75W56FU-TE12L	TC75W56FU-TE12L
26	U457	1203-002142	IC;MM1448CYFE	MM1448CYFE
27	U645	1203-002187	IC;MAX6326	MAX6326
28	U108	1205-001881	IC;VP40575	VP40575
29	U305	1205-001935	IC;HD155128TF	HD155128TF
30	U302	1209-001337	IC;SI4133-MLP28	SI4133-MLP28
31	TH101	1404-001005	IC;NTH5G40B473J01TE	NTH5G40B473J01TE
32	R331	2007-000138	R-CHIP;100,5%	RK73K1ETP101J
33	R174,R177	2007-000139	R-CHIP;220,5%	ERJ2GEJ221X
34	R141,R303,R305,R308	2007-000140	R-CHIP;1K,5%	RK73K1ETP102J
35	R313,R315,R319	2007-000140	R-CHIP;1K,5%	RK73K1ETP102J
36	R681,R683	2007-000140	R-CHIP;1K,5%	RK73K1ETP102J
37	R686	2007-000140	R-CHIP;1K,5%	RK73K1ETP102J
38	R696	2007-000140	R-CHIP;1K,5%	RK73K1ETP102J
39	R700	2007-000143	R-CHIP;4.7K,5%	RK73K1ETP472J

	SEC CODE	Reference	Part Description	Vendor Part No.
40	R103,R105,R106,R114	2007-000148	R-CHIP;10K,5%	RK73K1ETP103J
41	R121,R125,R154,R155	2007-000148	R-CHIP;10K,5%	RK73K1ETP103J
42	R156,R159,R161,R162	2007-000148	R-CHIP;10K,5%	RK73K1ETP103J
43	R163,R165,R178,R182	2007-000148	R-CHIP;10K,5%	RK73K1ETP103J
44	R332,R344,R347,R673	2007-000148	R-CHIP;10K,5%	RK73K1ETP103J
45	R678,R694	2007-000148	R-CHIP;10K,5%	RK73K1ETP103J
46	R136	2007-000152	R-CHIP;20K,5%	RK73K1ETP203J
47	R144,R170	2007-000157	R-CHIP;47K,5%	RK73K1ETP473J
48	R187	2007-000159	R-CHIP;56K,5%	ERJ2GEJ563X
49	R108,R109,R116,R146	2007-000162	R-CHIP;100K,5%	RK73K1ETP104J
50	R149,R151,R157,R166	2007-000162	R-CHIP;100K,5%	RK73K1ETP104J
51	R167,R168,R169	2007-000162	R-CHIP;100K,5%	RK73K1ETP104J
52	R181,R565,R567,R695	2007-000162	R-CHIP;100K,5%	RK73K1ETP104J
53	R702,R706,R647,R648	2007-000162	R-CHIP;100K,5%	RK73K1ETP104J
54	R184,R185,R186	2007-000170	R-CHIP;1M,5%	ERJ2GEJ105X
55	R312	2007-000172	R-CHIP;10,5%	ERJ2GEJ100X
56	R369,R370	2007-000173	R-CHIP;22,5%	ERJ2GEJ220X
57	R371	2007-000174	R-CHIP;47,5%	ERJ2GEJ470X
58	R310,R301	2007-000242	R-CHIP;1.5K,5%	ERJ2GEJ152X
59	R115	2007-000982	R-CHIP;5.6K,5%	ERJ2GEJ562X
60	R329	2007-001119	R-CHIP;680,5%	ERJ2GEJ681X
61	R314,R360	2007-001298	R-CHIP;51,5%	ERJ2GEJ510X
62	R110,R175,R176,R323	2007-002796	R-CHIP;510,5%	ERJ2GEJ511X
63	R324	2007-002797	R-CHIP;560,5%	ERJ2GEJ561X
64	R304	2007-007021	R-CHIP;75K,5%	ERJ2GEJ753X
65	R333	2007-007135	R-CHIP;18K,1%	ERJ2RKF1802X
66	R322	2007-007137	R-CHIP;1.2K,1%	ERJ2GEF122X
67	R368	2007-007309	R-CHIP;12K,1%	RK73H1ETP1202F
68	R321	2007-007310	R-CHIP;8.2K,1%	RK73H1ETP8201F
69	R326	2007-007311	R-CHIP;22K,1%	RK73H1ETP2202F
70	R338,R339,R340,R341	2007-007313	R-CHIP;6.8K,1%	RK73H1ETP6801F
71	R361	2007-007315	R-CHIP;3.9K,1%	RK73H1ETP3901F
72	R120,R122,R123,R126	2007-007317	R-CHIP;2.2K,1%	RK73H1ETP3901F
73	R130,R134,R140,R143	2007-007318	R-CHIP;1K,1%	RK73H1ETP1001F
74	R327	2007-007318	R-CHIP;1K,1%	RK73H1ETP1001F
75	R153	2007-007480	R-CHIP;130K,1%	RK73H1ETP1303F
76	R318	2007-007588	R-CHIP;1.8K,1%	RK73H1ETP1801F
77	R362	2007-008117	R-CHIP;2.7Kohm,1%	RK73H1ETP2701F
78	R158,R302	2007-007771	R-CHIP;0,5%	ERJ2GEJ0R0E
79	R311,R351,R357	2007-007771	R-CHIP;0,5%	ERJ2GEJ0R0E
80	R358,R372,R587	2007-007771	R-CHIP;0,5%	ERJ2GEJ0R0E
81	R705	2007-007771	R-CHIP;0,5%	ERJ2GEJ0R0E
82	R152	2007-007981	R-CHIP;180K,1%	ERJ2GEJ0R0E

	SEC CODE	Reference	Part Description	Vendor Part No.
83	R101	2011-001345	R-CHIP;EXB28V103JX	EXB28V103JX
84	C129,C135,C138	2203-000233	C-CERAMIC,CHIP;C101J,100PF,50V	GRM36C0G101J50PT
85	C333,C351,C695	2203-000233	C-CERAMIC,CHIP;C101J,100PF,50V	GRM36C0G101J50PT
86	C706,C725	2203-000233	C-CERAMIC,CHIP;C101J,100PF,50V	GRM36C0G101J50PT
87	C107,C119,C147	2203-000254	C-CERAMIC,CHIP;C103K,10NF,16V	GRM36X7R103K16PT
88	C151,C164,C171,C181	2203-000254	C-CERAMIC,CHIP;C103K,10NF,16V	GRM36X7R103K16PT
89	C183,C197,C306	2203-000254	C-CERAMIC,CHIP;C103K,10NF,16V	GRM36X7R103K16PT
90	C319,C320,C321,C366	2203-000254	C-CERAMIC,CHIP;C103K,10NF,16V	GRM36X7R103K16PT
91	C374,C382,C549	2203-000254	C-CERAMIC,CHIP;C103K,10NF,16V	GRM36X7R103K16PT
92	C550,C551	2203-000254	C-CERAMIC,CHIP;C103K,10NF,16V	GRM36X7R103K16PT
93	C724	2203-000278	C-CERAMIC,CHIP;C100D,10PF,50V	GRM36C0G100D50PT
94	C313,C314	2203-000330	C-CERAMIC,CHIP;C120J,12PF,50V	GRM36C0G120J50PT
95	C300	2203-000359	C-CERAMIC,CHIP;C151J,150PF,50V	GRM36C0G151J50PT
96	C348	2203-000425	C-CERAMIC,CHIP;C180J,18PF,50V	GRM36C0G180J50PT
97	C302,C307,C324,C325	2203-000438	C-CERAMIC,CHIP;C102K,1NF,50V	GRM36X7R102K50PT
98	C326,C327,C330,C338	2203-000438	C-CERAMIC,CHIP;C102K,1NF,50V	GRM36X7R102K50PT
99	C344,C349,C358,C360	2203-000438	C-CERAMIC,CHIP;C102K,1NF,50V	GRM36X7R102K50PT
100	C362,C373,C357	2203-000438	C-CERAMIC,CHIP;C102K,1NF,50V	GRM36X7R102K50PT
101	C406	2203-000585	C-CERAMIC,CHIP;C221K,220PF,50V	GRM36X7R221K50PT
102	C353	2203-000628	C-CERAMIC,CHIP;C220J,22PF,50V	GRM36C0G220J50PT
103	C152,C153,C158	2203-000679	C-CERAMIC,CHIP;C270J,27PF,50V	GRM36C0G270J50PT
104	C159,C161,C165,C167	2203-000679	C-CERAMIC,CHIP;C270J,27PF,50V	GRM36C0G270J50PT
105	C337,C339	2203-000679	C-CERAMIC,CHIP;C270J,27PF,50V	GRM36C0G270J50PT
106	C345,C356,C369	2203-000679	C-CERAMIC,CHIP;C270J,27PF,50V	GRM36C0G270J50PT
107	C394,C709	2203-000679	C-CERAMIC,CHIP;C270J,27PF,50V	GRM36C0G270J50PT
108	C118,C121,C134,C141	2203-000812	C-CERAMIC,CHIP;C330J,33PF,50V	GRM36C0G330J50PT
109	C148,C177,C182	2203-000812	C-CERAMIC,CHIP;C330J,33PF,50V	GRM36C0G330J50PT
110	C193	2203-000812	C-CERAMIC,CHIP;C330J,33PF,50V	GRM36C0G330J50PT
111	C711,C712	2203-000812	C-CERAMIC,CHIP;C330J,33PF,50V	GRM36C0G330J50PT
112	C334,C627	2203-000995	C-CERAMIC,CHIP;C470J,47PF,50V	GRM36C0G470J50PT
113	C334,C627	2203-000995	C-CERAMIC,CHIP;C470J,47PF,50V	GRM36C0G470J50PT
114	C361	2203-001072	C-CERAMIC,CHIP;0.056nF,5%	GRM36C0G560J50PT
115	C178,C180	2203-001201	C-CERAMIC,CHIP;0.007nF,0.5pF,50V	GRM36C0G070D50PT
116	C323	2203-001221	C-CERAMIC,CHIP;C821K,820PF,50V	GRM36X7R821K50PT
117	C312	2203-001383	C-CERAMIC,CHIP;C0R5C,0.5PF,50V	GRM36C0G0R5C50PT
118	C301,C315	2203-002525	C-CERAMIC,CHIP;C561K,560PF,50V	GRM36X7R561K50PT
119	C403	2203-002687	C-CERAMIC,CHIP;C122K,1.2NF,50V	GRM36X7R122K50PT
120	C155,C168,C170	2203-003054	C-CERAMIC,CHIP;C090C,9PF,50V	GRM36C0G090C50PT
121	C400	2203-005054	C-CERAMIC,CHIP;C4R7C,4.7PF,50V	GRM36C0G4R7C50PT
122	C404,C340	2203-005056	C-CERAMIC,CHIP;C6R8C,6.8PF,50V	GRM36C0G6R8D50PT
123	C378,C379	2203-005057	C-CERAMIC,CHIP;C8R2C,8.2PF,50V	GRM36C0G8R2D50PT
124	C102,C106,C114,C116	2203-005061	C-CERAMIC,CHIP;C104Z,100NF,16V	GRM36Y5V104Z16PT
125	C163,C173,C174,C186	2203-005061	C-CERAMIC,CHIP;C104Z,100NF,16V	GRM36Y5V104Z16PT

	SEC CODE	Reference	Part Description	Vendor Part No.
126	C205,C303,C304	2203-005061	C-CERAMIC,CHIP;C104Z,100NF,16V	GRM36Y5V104Z16PT
127	C308,C316	2203-005061	C-CERAMIC,CHIP;C104Z,100NF,16V	GRM36Y5V104Z16PT
128	C705	2203-005061	C-CERAMIC,CHIP;C104Z,100NF,16V	GRM36Y5V104Z16PT
129	C104,C125	2203-005065	C-CERAMIC,CHIP;C105Z,1UF,10V	GRM39Y5V105Z10PT
130	C702,C743	2203-005065	C-CERAMIC,CHIP;C105Z,1UF,10V	GRM39Y5V105Z10PT
131	C352	2203-005138	C-CERAMIC,CHIP;C182K,1.8NF,50V	GRM36X7R182K50PT
132	C309,C310	2203-005382	C-CERAMIC,CHIP;C060B,6PF,50V	GRM36C0G060B50PT
133	C364	2203-005446	C-CERAMIC,CHIP;C2R7B,2.7PF,50V	GRM36C0G2R7B50PT
134	C335	2203-005450	C-CERAMIC,CHIP;C5R6B,5.6PF,50V	GRM36C0G5R6B50PT
135	C187,C188	2203-005480	C-CERAMIC,CHIP;C333K,33NF,10V	GRM36X7R333K10PT
136	C184	2203-005481	C-CERAMIC,CHIP;C473K,47NF,10V	GRM36X7R473K10PT
137	C146,C149	2203-005503	C-CERAMIC,CHIP;C1801J,180PF,25V	GRM36C0H181J25PT
138	C117,C124	2203-005664	C-CERAMIC,CHIP;C475K,4.7UF,6.3V	GRM40034X5R475K6.3PT
139	C710	2404-000318	C-TA,CHIP;6.8UF/16V	TCSCS1C685MBAR
140	C105	2404-001105	C-TA,CHIP;10UF/6.3V	TAJR106M006R
141	C204	2404-001162	C-TA,CHIP;F950G476MAAJZTQ2	F950G476MAAJZTQ2
142	L325	2703-001174	INDUCTOR-SMD;LL1608-FH33NJ	LL1608-FH33NJ
143	L305,L306	2703-001293	INDUCTOR-SMD;HK1608-82NJ-T	HK1608-82NJ-T
144	L308	2703-001514	INDUCTOR-SMD;0603CS-68NXJBC	0603CS-68NXJBC
145	L310	2703-001685	INDUCTOR-SMD;0603CS-82NXJBC	0603CS-82NXJBC
146	L385	2703-001708	INDUCTOR-SMD;HK1005-5N6K-T	HK1005-5N6K-T
147	L316	2703-001726	INDUCTOR-SMD;LL1005-FH27NJ	LL1005-FH27NJ
148	L323,L324	2703-001727	INDUCTOR-SMD;LL1005-FH22NJ	LL1005-FH22NJ
149	L635	2703-001730	INDUCTOR-SMD;LL1005-FH15NJ	LL1005-FH15NJ
150	L318,L634	2703-001734	INDUCTOR-SMD;LL1005-FH6N8J	LL1005-FH6N8J
151	L301	2703-001750	INDUCTOR-SMD;LL1005-FH2N2S	LL1005-FH2N2S
152	L101	2703-001752	INDUCTOR-SMD;LL1005-FH39NJ	LL1005-FH39NJ
153	L304	2703-001786	INDUCTOR-SMD;LL1005-FH10NJ	LL1005-FH10NJ
154	L637,L638	2703-001798	INDUCTOR-SMD;HK1005-2N2S	HK1005-2N2S
155	L303	2703-001944	INDUCTOR-SMD;LL1055-F27NJ	LL1055-F27NJ
156	L639,L613	2703-001954	INDUCTOR-SMD;2.7nH	HK1005-2N7S-T
157	L636	2703-001992	INDUCTOR-SMD;MLK1005S1N0ST	MLK1005S1N0ST
158	OSC101	2801-003856	COMP-SMD;MC-146(32.768KHz,20ppm)	MC-146
159	U303	2809-001237	COMP-SMD;KT16-KEU28L-13.000M	KT16-KEU28L-13.000M
160	F306	2901-001116	COMP-SMD;NFM39R12C471T1	NFM39R12C471T1
161	U601	2903-001266	COMP-SMD;MKFC225.000MBA701X-TC11	MKFC225.000MBA701X-TC11
162	F303	2904-001226	COMP-SMD;B4121	B4121
163	F302	2904-001228	COMP-SMD;B4133	B4133
164	U603	2904-001235	COMP-SMD;FAR-G6CH-1G8425-L218	FAR-G6CH-1G8425-L218
165	U318	4709-001174	COMP-SMD;LDC15D140A0001	DC15D140A0001
166	ZD105	1405-001082	IC;VC040205X150R	VC040205X150R

3-2 Main Parts List Bottom

	SEC CODE	Reference	Part Description	Vendor Part No.
1	J301	3705-001239	COMP-SMD;MHC-175	MHC-175
2	L302	2703-001772	INDUCTOR-SMD;18NH,5%,1.0X0.5X0.5MM	MLK1005S18NJ
3	F307	2901-001116	COMP-SMD;NFM39R12C471T1	FM39R12C471T1
4	R330	2007-001305	R-CHIP;120,5%	ERJ2GEJ121X
5	C747	2203-005057	C-CERAMIC,CHIP;C8R2C,8.2PF,50V	GRM36C0G8R2D50PT
6	C402	2203-000812	C-CERAMIC,CHIP;C330J,33PF,50V	GRM36C0G330J50PT
7	C756	2404-001105	C-TA,CHIP;10UF/6.3V	TAJR106M006R
8	C396	2404-001210	C-TA,CHIP;220UF/6.3V	952D227X06R3U2T
9	U304	2909-001126	COMP-SMD;SHS-L090DE	SHS-L090DE
10	U312	1201-001689	IC;PF08107B-TB	PF08107B-TB
11	L311,L314	2703-001723	INDUCTOR-SMD;LL1005-FH33NJ	LL1005-FH33NJ
12	R335,R366	2007-002965	R-CHIP;15,5%	RK73K1ETP150J
13	R364	2007-007009	R-CHIP;75ohm,5%	ERJ2GEJ750X
14	R365,R346	2007-001288	R-CHIP;18,5%	ERJ2GEJ180X
15	R363	2007-003022	R-CHIP;62,5%	ERJ2GEJ620X
16	C697	2203-000812	C-CERAMIC,CHIP;C330J,33PF,50V	GRM36C0G330J50PT
17	C387	2203-000679	C-CERAMIC,CHIP;C270J,27PF,50V	GRM36C0G270J50PT
18	C387	2203-000812	C-CERAMIC,CHIP;C330J,33PF,50V	GRM36C0G330J50PT
19	C377	2203-000254	C-CERAMIC,CHIP;C103K,10NF,16V	GRM36X7R103K16PT
20	R667	2007-000138	R-CHIP;100,5%	RK73K1ETP101J
21	C383	2203-000278	C-CERAMIC,CHIP;C100D,10PF,50V	GRM36C0G100D50PT
22	R666	2007-000174	R-CHIP;47,5%	ERJ2GEJ470X
23	R337	2007-001313	R-CHIP;330,5%	ERJ2GEJ331X
24	C755	2203-000995	C-CERAMIC,CHIP;C470J,47PF,50V	GRM36C0G470J50PT
25	C754	2203-000995	C-CERAMIC,CHIP;C470J,47PF,50V	GRM36C0G470J50PT
26	ZD107	1405-001082	IC;VC040205X150R	VC040205X150R
27	C169	2203-000679	C-CERAMIC,CHIP;C270J,27PF,50V	GRM36C0G270J50PT
28	C122	2203-005444	C-CERAMIC,CHIP;C030B,3PF,50V	GRM36C0G470J112PT
29	J101	3722-001587	COMP-SMD;02-828D0-53BKA	02-828D0-53BKA
30	ZD108	0406-001083	TR-SMALL SIGNAL;ESDA6V1W5	ESDA6V1W5
31	V105	1405-001019	IC;VC060305A150R	VC060305A150R
32	ZD102	1405-001082	IC;VC040205X150R	VC040205X150R
33	C723	2203-005444	C-CERAMIC,CHIP;C030B,3PF,50V	GRM36C0G470J112PT
34	C719	2203-000679	C-CERAMIC,CHIP;C270J,27PF,50V	GRM36C0G270J50PT
35	C752	2203-000679	C-CERAMIC,CHIP;C270J,27PF,50V	GRM36C0G270J50PT
36	C722	2203-005444	C-CERAMIC,CHIP;C030B,3PF,50V	GRM36C0G470J112PT
37	ZD101	1405-001082	IC;VC040205X150R	VC040205X150R
38	C718	2203-000679	C-CERAMIC,CHIP;C270J,27PF,50V	GRM36C0G270J50PT
39	V102	1405-001019	IC;VC060305A150R	IC;VC060305A150R
40	R674	2007-000148	R-CHIP;10K,5%	RK73K1ETP103J
41	R675	2007-000148	R-CHIP;10K,5%	RK73K1ETP103J
42	U640	0801-002540	IC;NC7SZ19P6X	NC7SZ19P6X

	SEC CODE	Reference	Part Description	Vendor Part No.
43	R119	2007-007771	R-CHIP;0,5%	ERJ2GEJ0R0E
44	C753	2203-000679	C-CERAMIC,CHIP;C270J,27PF,50V	GRM36C0G270J50PT
45	CN105	3710-001428	COMP-SMD;AXK5F24335J	AXK5F24335J
46	U200	2806-001239	COMP-SMD;V0F1748C28KRD	V0F1748C28KRD
47	C391	2203-005065	C-CERAMIC,CHIP;C105Z,1UF,10V	GRM36C0G470J101PT
48	C392	2203-000679	C-CERAMIC,CHIP;C270J,27PF,50V	GRM36C0G270J50PT
49	R343	2007-007771	R-CHIP;0,5%	ERJ2GEJ0R0E
50	R331	2007-000138	R-CHIP;100,5%	RK73K1ETP101J
51	C365	2301-001232	C-CERAMIC,CHIP;470PF,50V	GRM36C0G470J125PT
52	R325	2007-001290	R-CHIP;24,5%	RK73K1ETP240J
53	C359	2301-001199	C-CERAMIC,CHIP;22NF,16V	GRM36C0G470J124PT
54	C750	2203-000679	C-CERAMIC,CHIP;C270J,27PF,50V	GRM36C0G270J50PT
55	C749	2203-000679	C-CERAMIC,CHIP;C270J,27PF,50V	GRM36C0G270J50PT
56	C748	2203-000679	C-CERAMIC,CHIP;C270J,27PF,50V	GRM36C0G270J50PT
57	R698	2007-000147	R-CHIP;8.2K,5%	ERJ2GEJ822X
58	C751	2203-000679	C-CERAMIC,CHIP;C270J,27PF,50V	GRM36C0G270J50PT
59	CN102	3709-001144	COMP-SMD;1318723-6	1318723-6
60	C744	2203-000812	C-CERAMIC,CHIP;C330J,33PF,50V	GRM36C0G330J50PT
61	R183	2007-000157	R-CHIP;47K,5%	RK73K1ETP473J
62	C192	2203-000812	C-CERAMIC,CHIP;C330J,33PF,50V	GRM36C0G330J50PT
63	R171	2007-000162	R-CHIP;100K,5%	RK73K1ETP104J
64	C157	2203-000812	C-CERAMIC,CHIP;C330J,33PF,50V	GRM36C0G330J50PT
65	C115	2203-000254	C-CERAMIC,CHIP;C103K,10NF,16V	GRM36X7R103K16PT
66	C732	2203-001221	C-CERAMIC,CHIP;C821K,820PF,50V	GRM36C0G470J58PT
67	C727	2203-001221	C-CERAMIC,CHIP;C821K,820PF,50V	GRM36C0G470J58PT
68	C729	2203-001221	C-CERAMIC,CHIP;C821K,820PF,50V	GRM36C0G470J58PT
69	R684	2007-000140	R-CHIP;1K,5%	RK73K1ETP102J
70	C730	2203-001221	C-CERAMIC,CHIP;C821K,820PF,50V	GRM36C0G470J58PT
71	R688	2007-000140	R-CHIP;1K,5%	RK73K1ETP102J
72	R680	2007-000140	R-CHIP;1K,5%	RK73K1ETP102J
73	R682	2007-000140	R-CHIP;1K,5%	RK73K1ETP102J
74	R685	2007-000140	R-CHIP;1K,5%	RK73K1ETP102J
75	R687	2007-000140	R-CHIP;1K,5%	RK73K1ETP102J
76	C734	2203-001221	C-CERAMIC,CHIP;C821K,820PF,50V	GRM36C0G470J58PT
77	C726	2203-001221	C-CERAMIC,CHIP;C821K,820PF,50V	GRM36C0G470J58PT
78	C728	2203-001221	C-CERAMIC,CHIP;C821K,820PF,50V	GRM36C0G470J58PT
79	C731	2203-001221	C-CERAMIC,CHIP;C821K,820PF,50V	GRM36C0G470J58PT
80	C733	2203-001221	C-CERAMIC,CHIP;C821K,820PF,50V	GRM36C0G470J58PT
81	C699	2404-001105	C-TA,CHIP;10UF/6.3V	GRM36C0G470J127PT
82	R164	2007-001308	R-CHIP;200,5%	ERJ2GEJ201X
83	C209	2404-001134	C-TA,CHIP;100UF/6.3V	GRM36C0G470J134PT
84	U117	1203-001702	IC;MAX1676EUB-T	MAX1676EUB-T

	SEC CODE	Reference	Part Description	Vendor Part No.
85	L102	2703-002025	INDUCTOR-SMD;BTC-0309-470	BTC-0309-470
86	F307	2203-005065	C-CERAMIC,CHIP;C105Z,1UF,10V	GRM36C0G470J101PT
87	C328	2404-001105	C-TA,CHIP;10UF/6.3V	GRM36C0G470J127PT
88	U463	1203-002227	IC;R5320G002-TR	R5320G002-TR
89	D108	0402-001331	TR-SMALL SIGNAL;CRS04-TE85L	CRS04-TE85L
90	C746	2203-003054	C-CERAMIC,CHIP;C090C,9PF,50V	GRM36C0G470J73PT
91	C704	2203-005061	C-CERAMIC,CHIP;C104Z,100NF,16V	GRM36C0G470J84PT
92	R671	2007-007107	R-CHIP;100K,1%	ERJ2RKF1003X
93	C555	2203-000679	C-CERAMIC,CHIP;C270J,27PF,50V	GRM36C0G270J50PT
94	C700	2404-001105	C-TA,CHIP;10UF/6.3V	GRM36C0G470J127PT
95	C535	2203-005065	C-CERAMIC,CHIP;C105Z,1UF,10V	GRM36C0G470J101PT
96	C708	2203-000254	C-CERAMIC,CHIP;C103K,10NF,16V	GRM36X7R103K16PT
97	C424	2203-001432	C-CERAMIC,CHIP;C473K,47NF,16V	GRM36C0G470J69PT
98	R699	2007-007771	R-CHIP;0,5%	ERJ2GEJ0R0E
99	R320	2007-007590	R-CHIP;82K,1%	RK73H1ETP8202F
100	U649	1203-001903	IC;LTC1986ES6	LTC1986ES6
101	C211	2203-000254	C-CERAMIC,CHIP;C103K,10NF,16V	GRM36X7R103K16PT
102	C208	2404-001105	C-TA,CHIP;10UF/6.3V	GRM36C0G470J127PT
103	C423	2203-005061	C-CERAMIC,CHIP;C104Z,100NF,16V	GRM36C0G470J84PT
104	R428	2007-003028	R-CHIP;750K,5%	ERJ2GEJ754X
105	R421	2007-000170	R-CHIP;1M,5%	ERJ2GEJ105X
106	C745	2404-001105	C-TA,CHIP;10UF/6.3V	GRM36C0G470J127PT
107	Q303	0501-002346	TR-SMALL SIGNAL;2SB1427	2SB1427
108	U116	1203-002077	IC;LP2985AIM5-3.3	LP2985AIM5-3.3
109	C190	2203-000233	C-CERAMIC,CHIP;C101J,100PF,50V	GRM36C0G101J50PT
110	C111	2203-000679	C-CERAMIC,CHIP;C270J,27PF,50V	GRM36C0G270J50PT
111	R328	2007-000142	R-CHIP;2.7K,5%	ERJ2GEJ272X
112	F307	3301-001208	COMP-SMD;BLM11P600SPT	BLM11P600SPT
113	U639	1203-002127	IC;LTC1734ES6-4.2#TR	LTC1734ES6-4.2#TR
114	BAT101	4302-001119	COMP-SMD;MS414 FL26N	MS414 FL26N
115	D110	0402-001331	TR-SMALL SIGNAL;CRS04-TE85L	CRS04-TE85L
116	R701	2007-000140	R-CHIP;1K,5%	RK73K1ETP102J
117	C713	2203-000254	C-CERAMIC,CHIP;C103K,10NF,16V	GRM36X7R103K16PT
118	R703	2007-007771	R-CHIP;0,5%	ERJ2GEJ0R0E
119	R703	1405-001082	IC;VC040205X150R	VC040205X150R
120	C721	2203-005057	C-CERAMIC,CHIP;C8R2C,8.2PF,50V	GRM36C0G470J80PT
121	C717	2203-000812	C-CERAMIC,CHIP;C330J,33PF,50V	GRM36C0G330J50PT
122	ZD109	1405-001082	IC;VC040205X150R	VC040205X150R
123	CN503	3711-004234	COMP-SMD;connector	AXK6F24335P
124	ZD205	1405-001082	IC;VC040205X150R	VC040205X150R
125	C738	2203-000679	C-CERAMIC,CHIP;C270J,27PF,50V	GRM36C0G470J84PT
126	ZD203	0406-001083	TR-SMALL SIGNAL;ESDA6V1W5	ESDA6V1W5

	SEC CODE	Reference	Part Description	Vendor Part No.
127	R209	2011-001344	R-CHIP;CRB2A4E101JT	CRB2A4E101JT
128	F201	2901-001116	COMP-SMD;NFM39R12C471T1	NFM39R12C471T1
129	F200	2901-001116	COMP-SMD;NFM39R12C471T1	NFM39R12C471T1
130	ZD201	0406-001104	TR-SMALL SIGNAL;ESDA6V1-5W6	ESDA6V1-5W6
131	R207	2011-001344	R-CHIP;CRB2A4E101JT	CRB2A4E101JT
132	C210	2203-005061	C-CERAMIC,CHIP;C104Z,100NF,16V	GRM36C0G470J84PT
133	C714	2203-000679	C-CERAMIC,CHIP;C270J,27PF,50V	GRM36C0G270J50PT
134	C201	2203-000679	C-CERAMIC,CHIP;C270J,27PF,50V	GRM36C0G270J50PT
135	L200	2703-001752	INDUCTOR-SMD;LL1005-FH39NJ	LL1005-FH39NJ
136	C740,C741	2203-000679	C-CERAMIC,CHIP;C270J,27PF,50V	GRM36C0G270J50PT
137	V205,V206	1405-001082	IC;VC040205X150R	VC040205X150R
138	C739	2203-000679	C-CERAMIC,CHIP;C270J,27PF,50V	GRM36C0G270J50PT
139	ZD202	0406-001104	TR-SMALL SIGNAL;ESDA6V1-5W6	ESDA6V1-5W6
140	R203	2007-007771	R-CHIP;0,5%	ERJ2GEJ0R0E
141	C715	2203-000679	C-CERAMIC,CHIP;C270J,27PF,50V	GRM36C0G270J50PT
142	CN502	3710-001599	COMP-SMD;1004-0018-305	1004-0018-305

4. Block Diagrams

4-1 Main Base Band

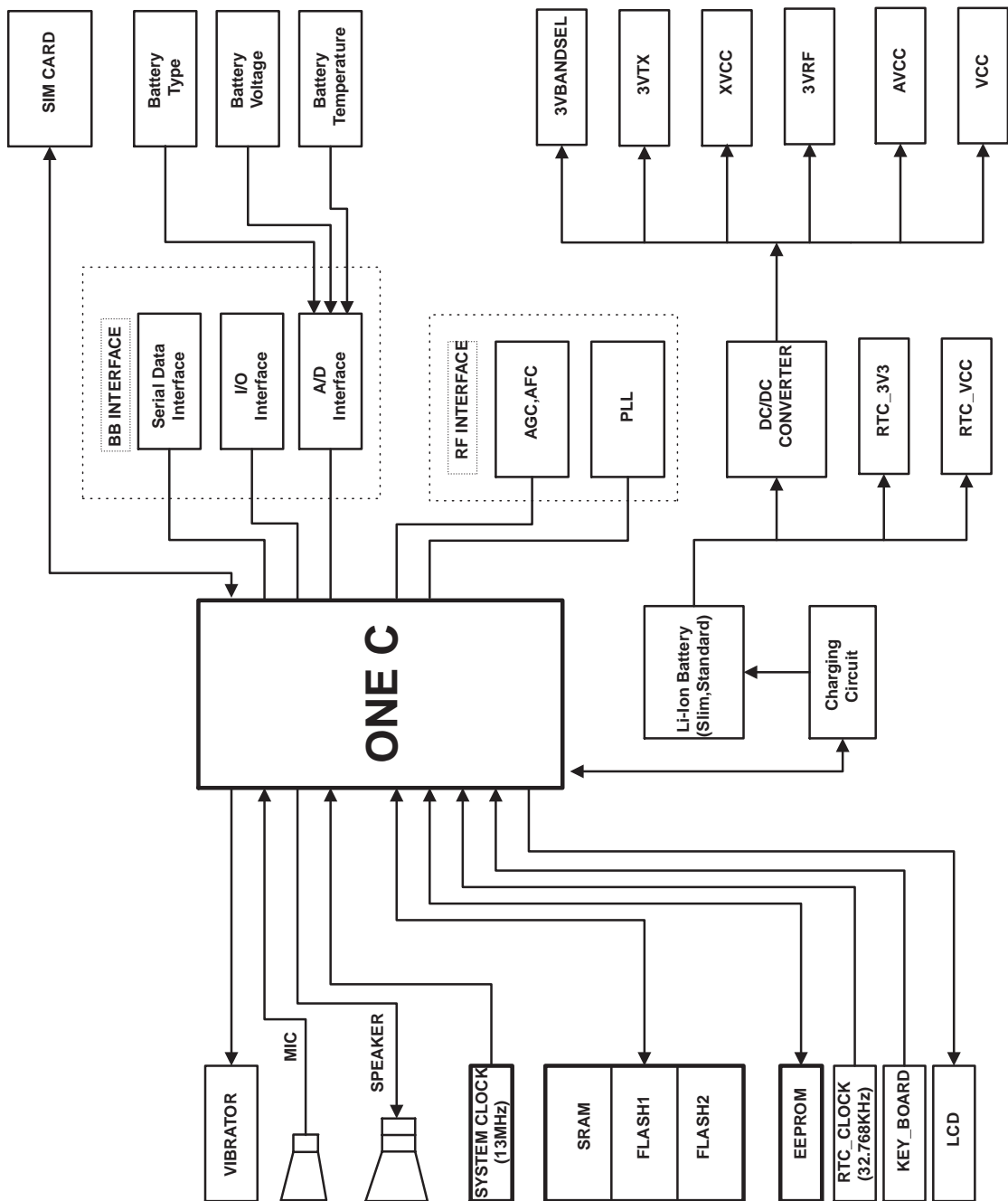

4-2 Main RF

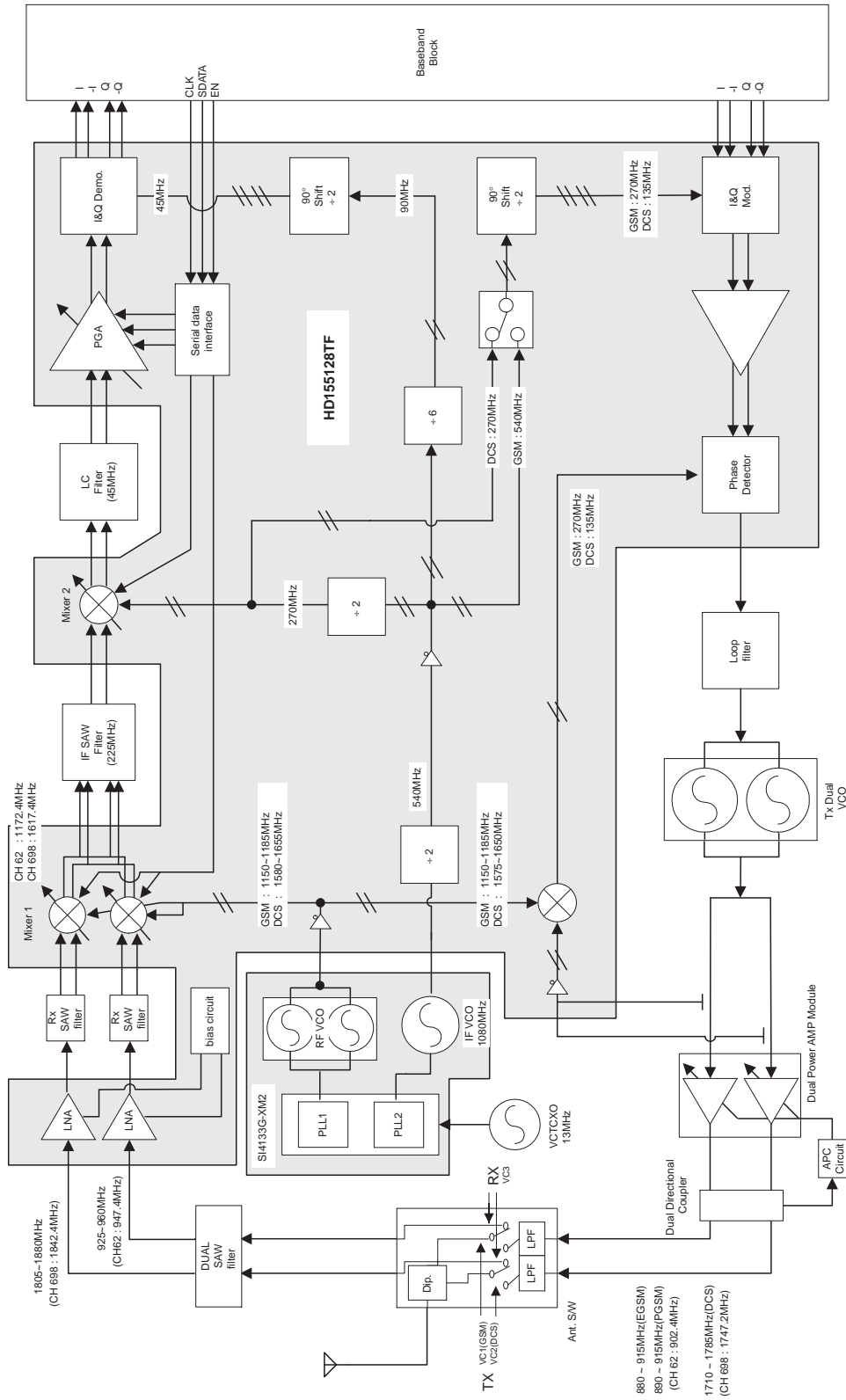

4-2-1 RF Transmit Part

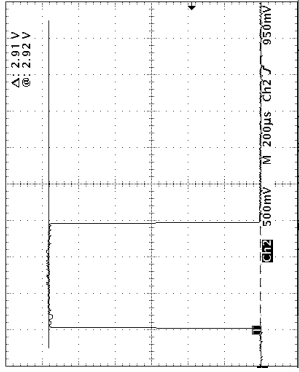

①

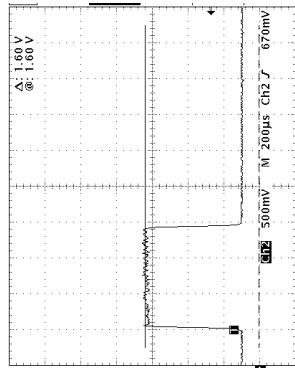

②

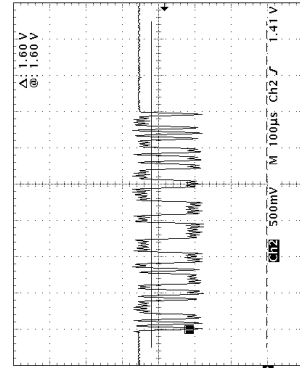

③

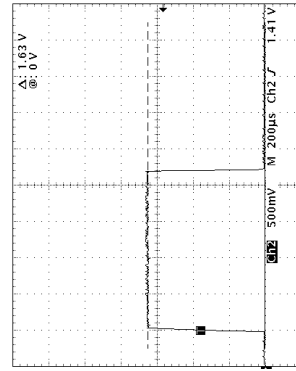
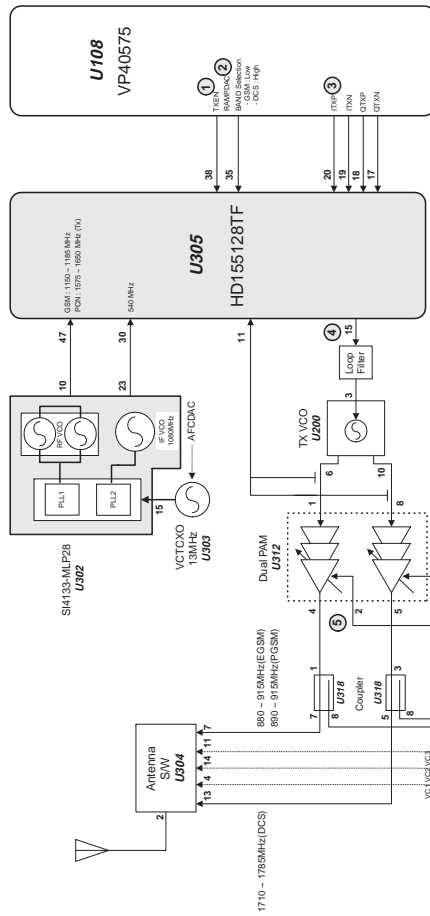

④

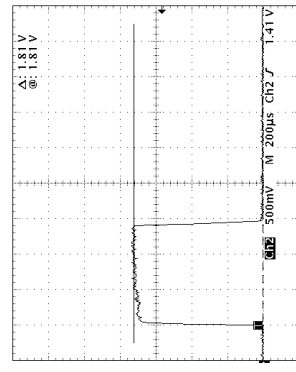

⑤

4-2-2 RF Receive Part

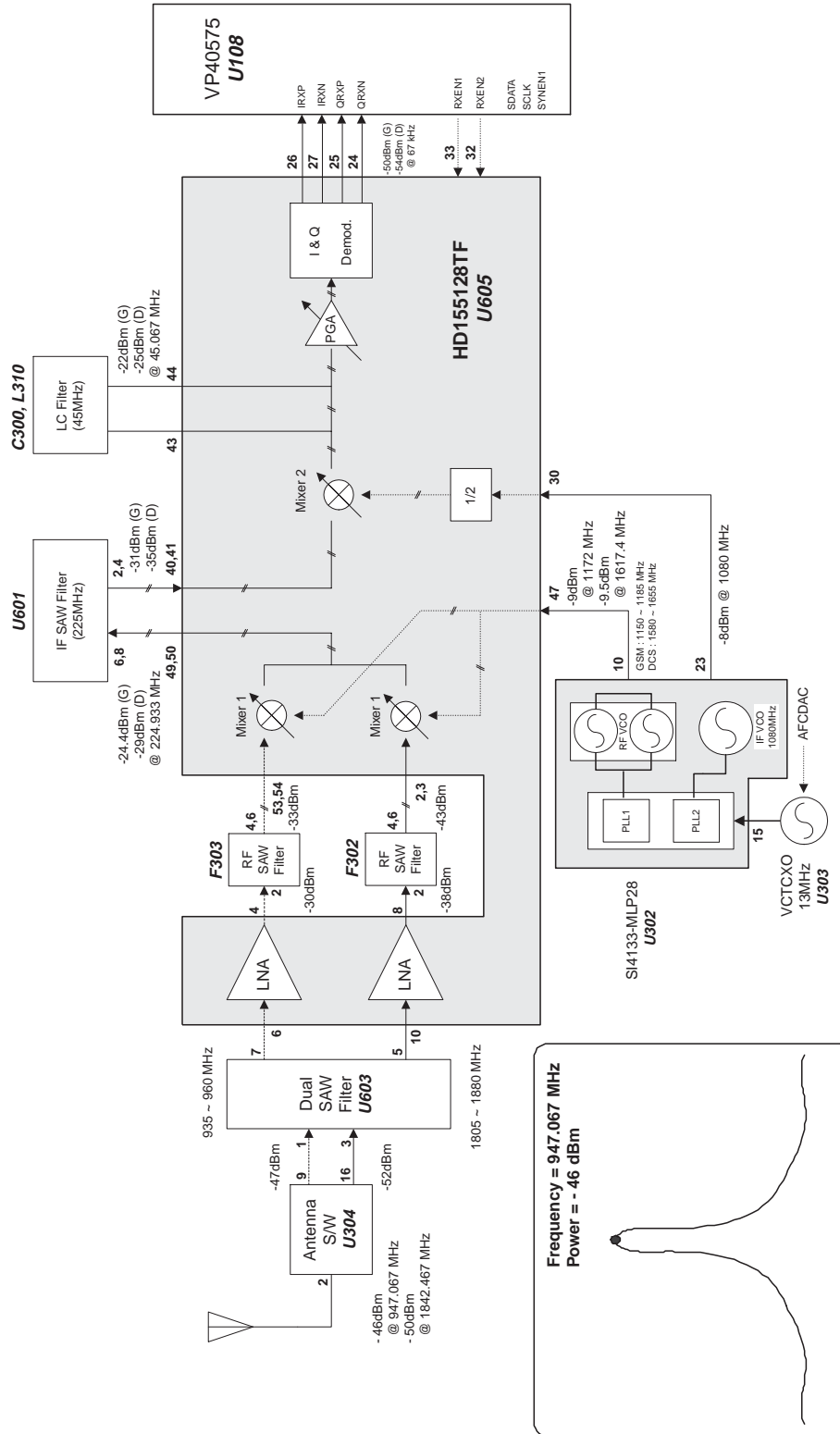

5. Flow Chart of Troubleshooting and Circuit Diagram

5-1 Power ON

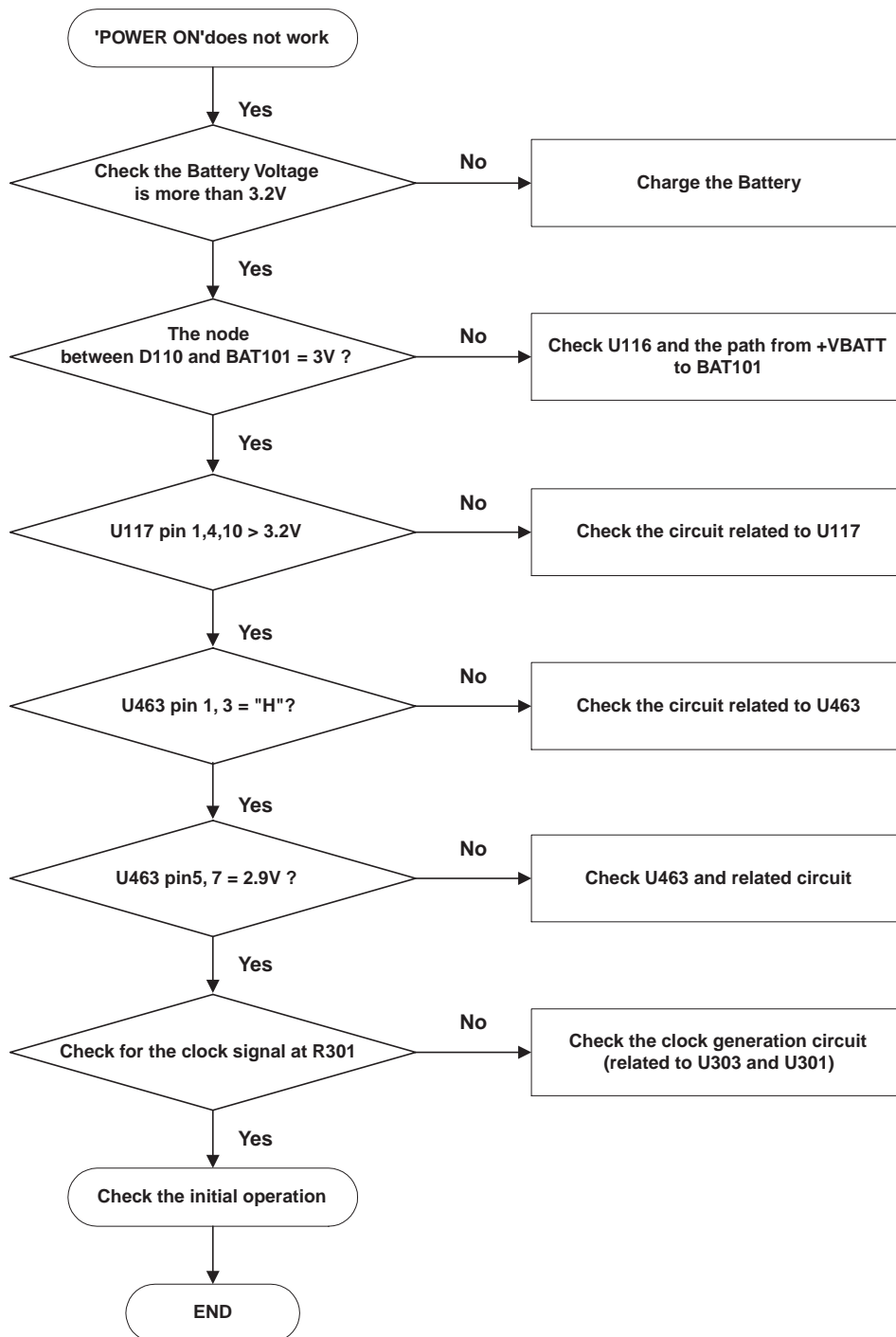

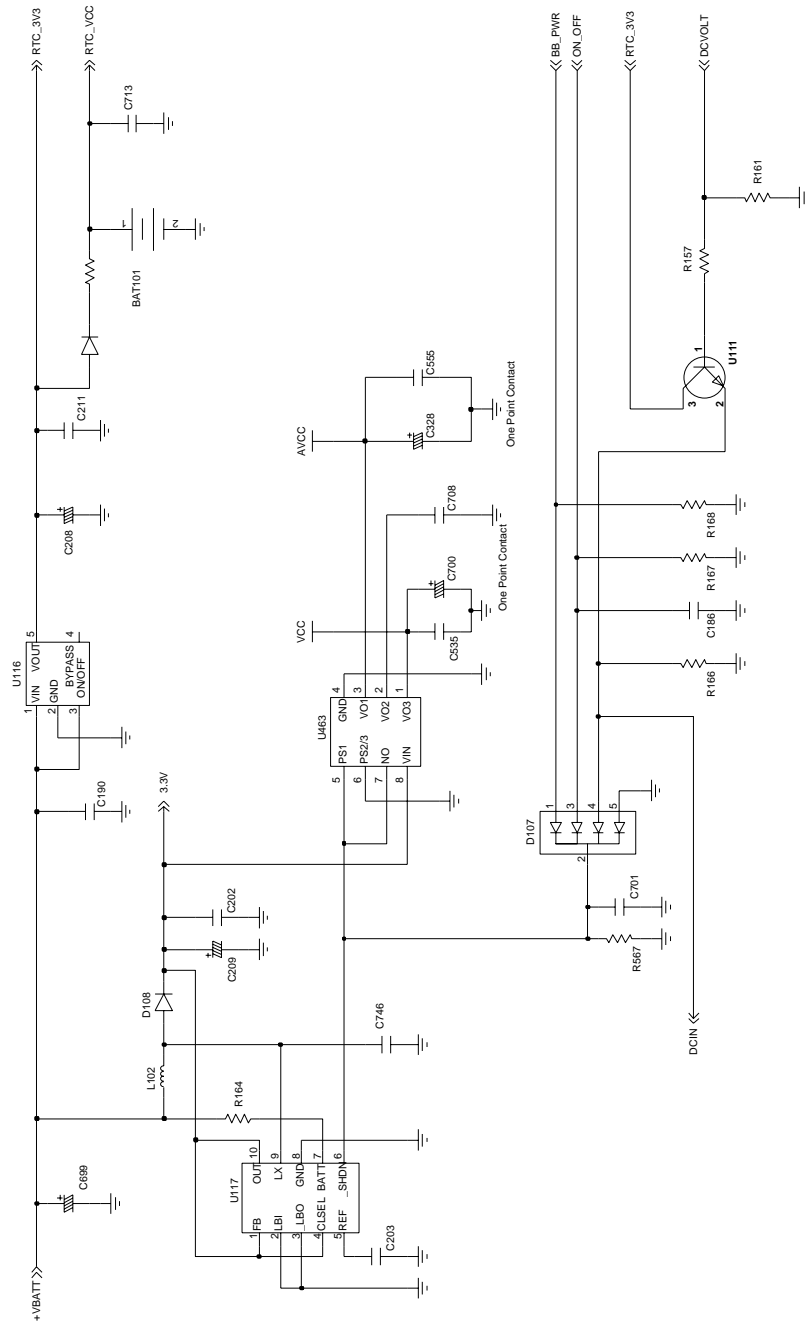

5-2 Initial

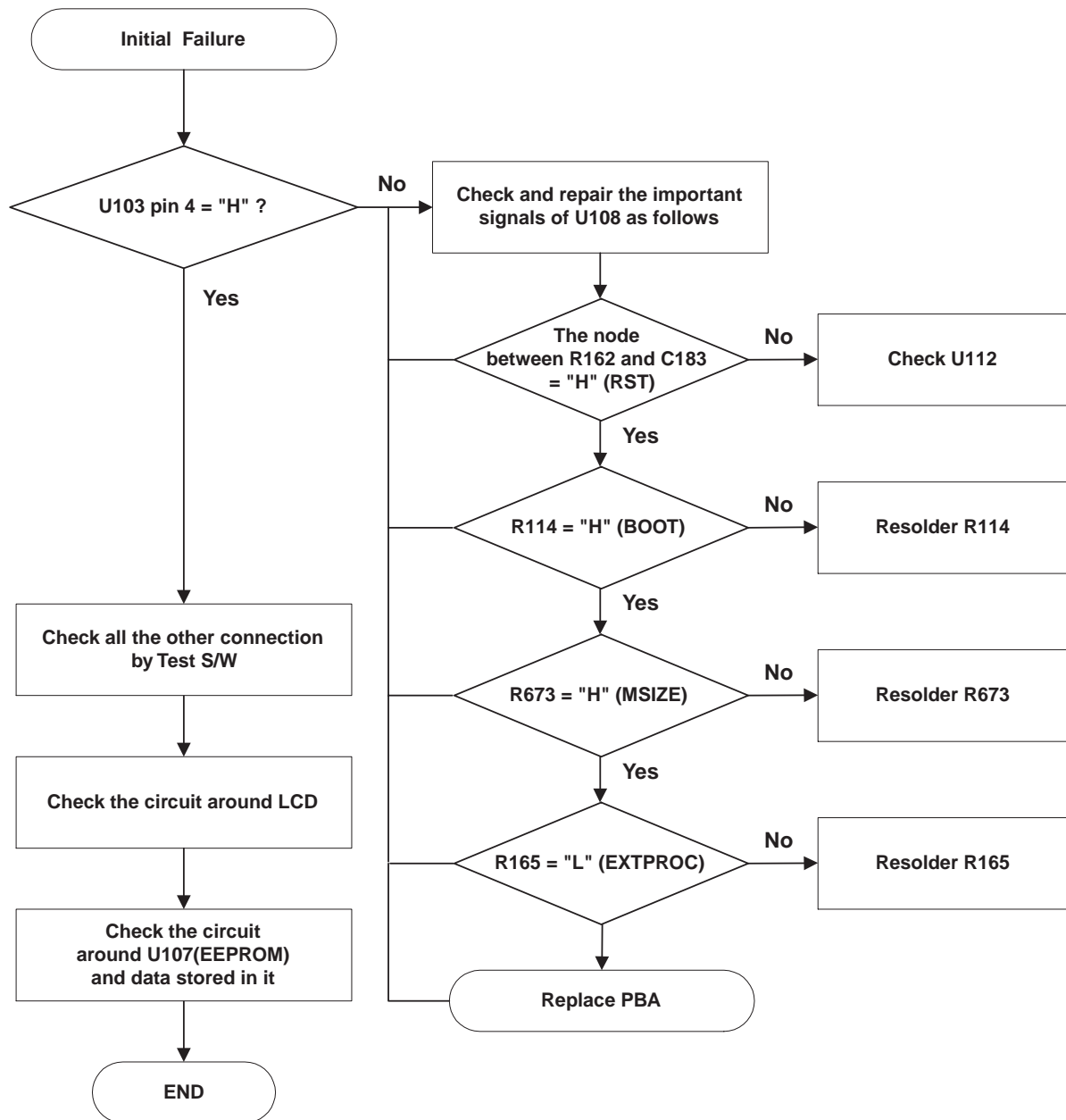

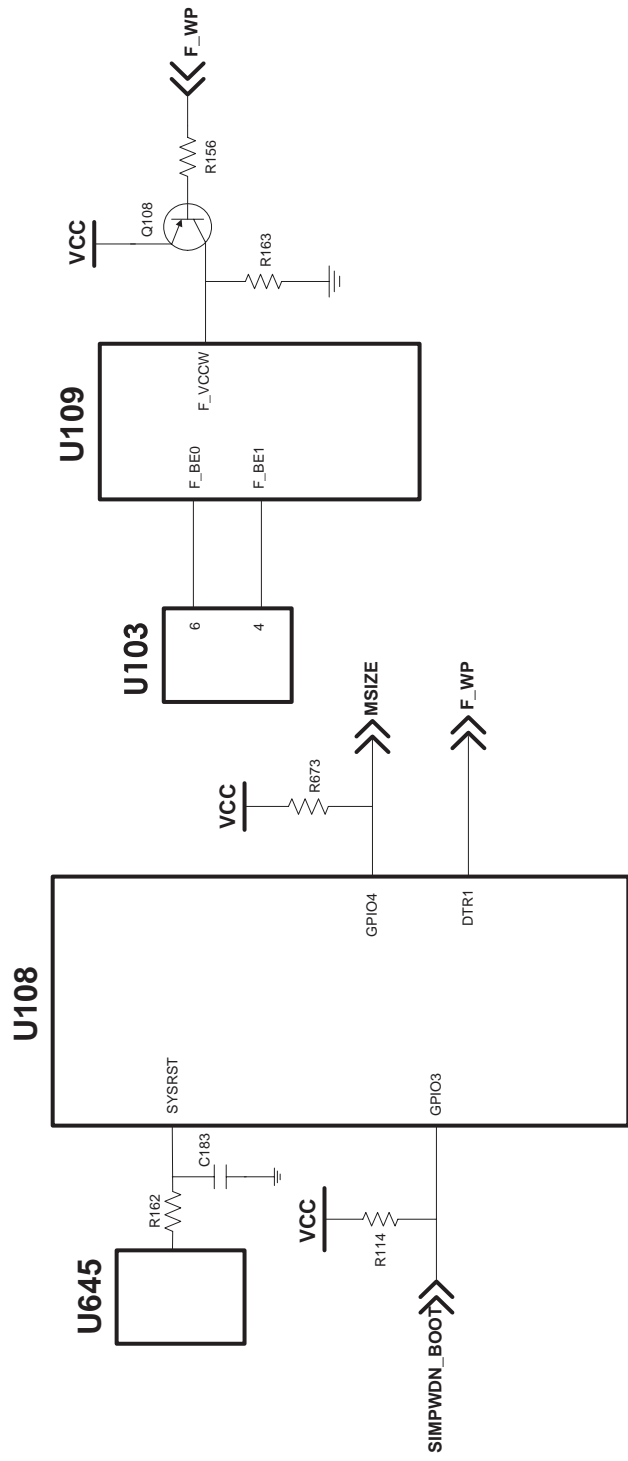

5-3 Charging Part

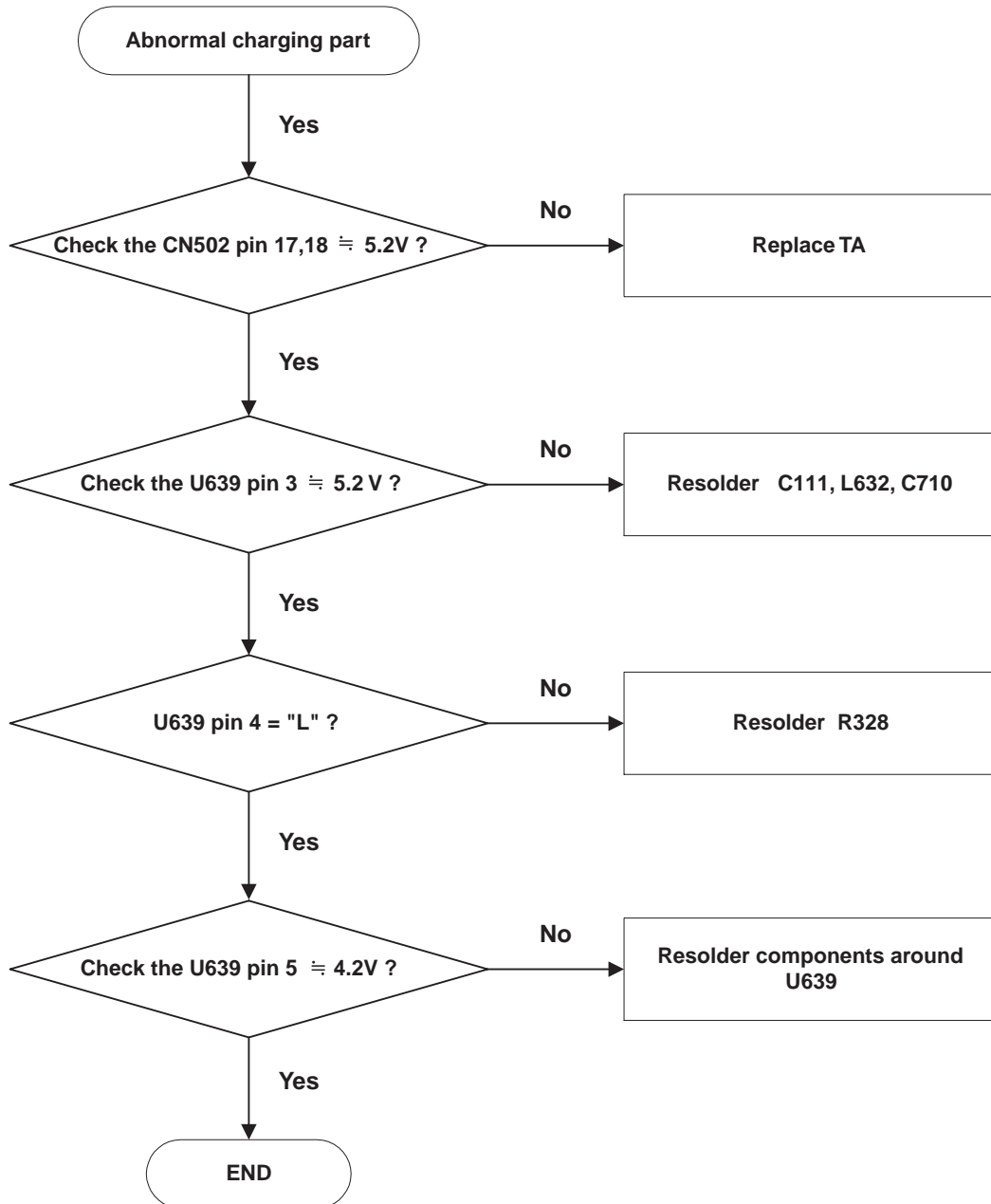

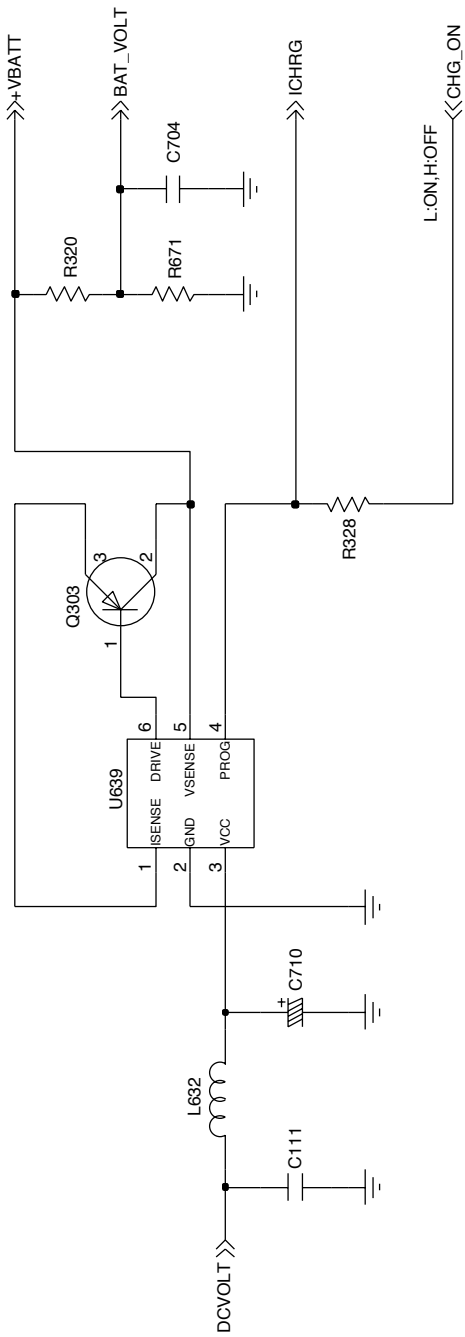

5-4 Sim Part

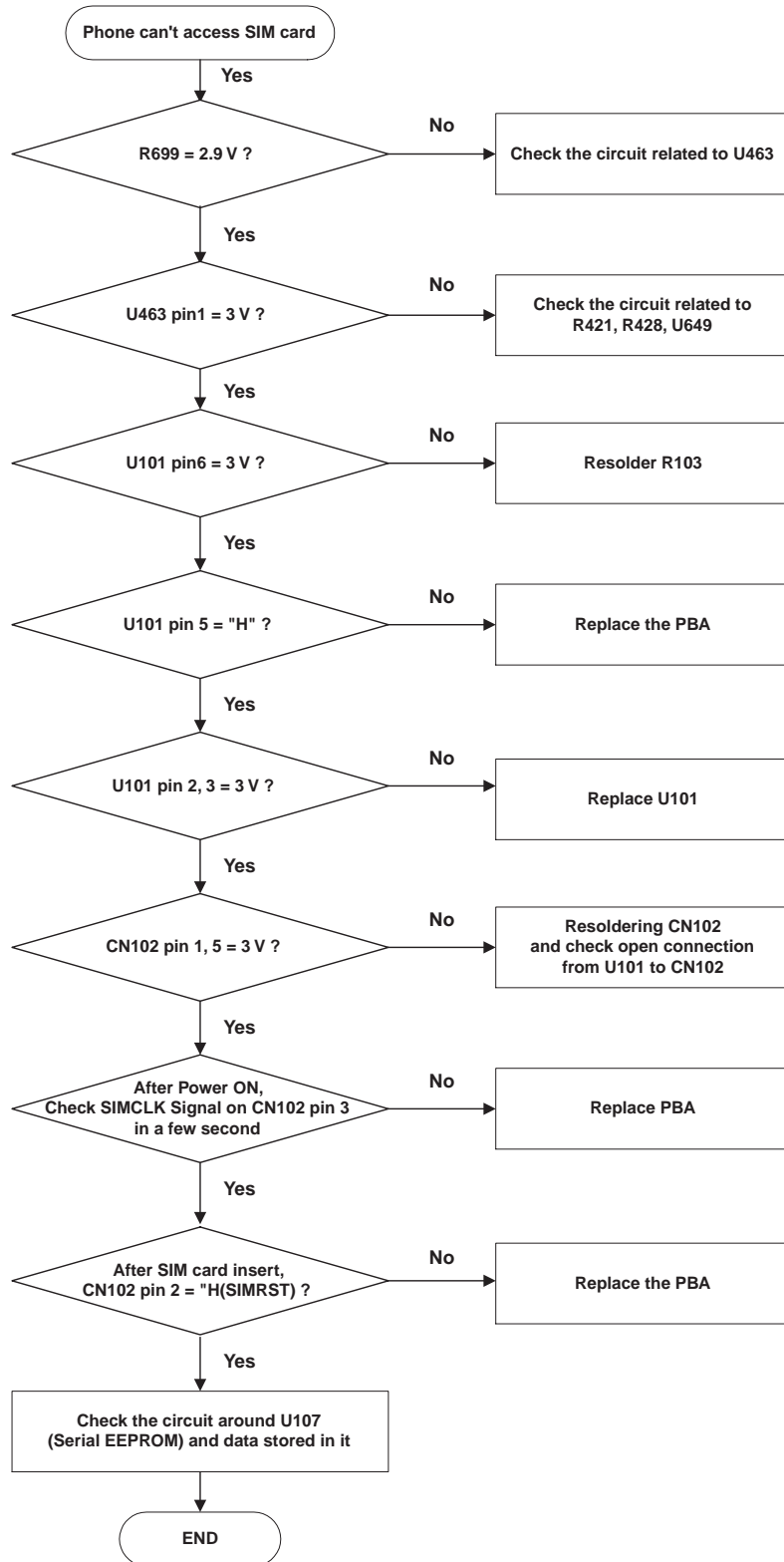

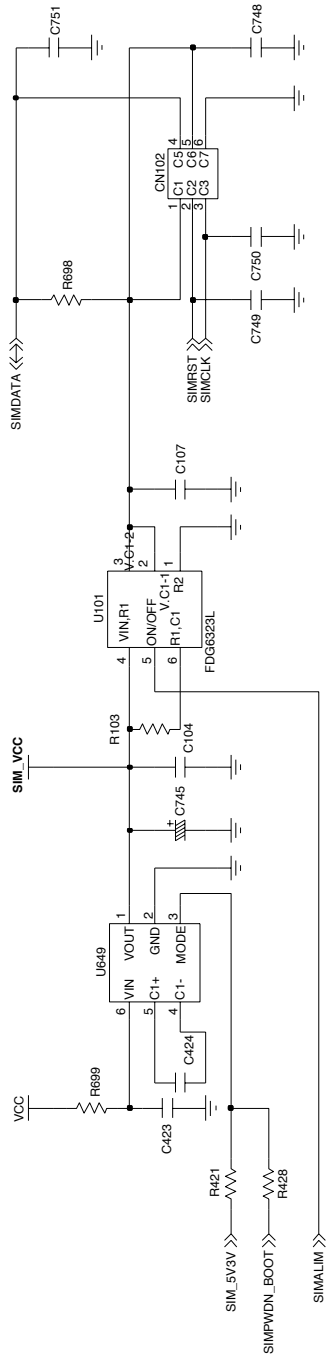

5-5 Microphone Part

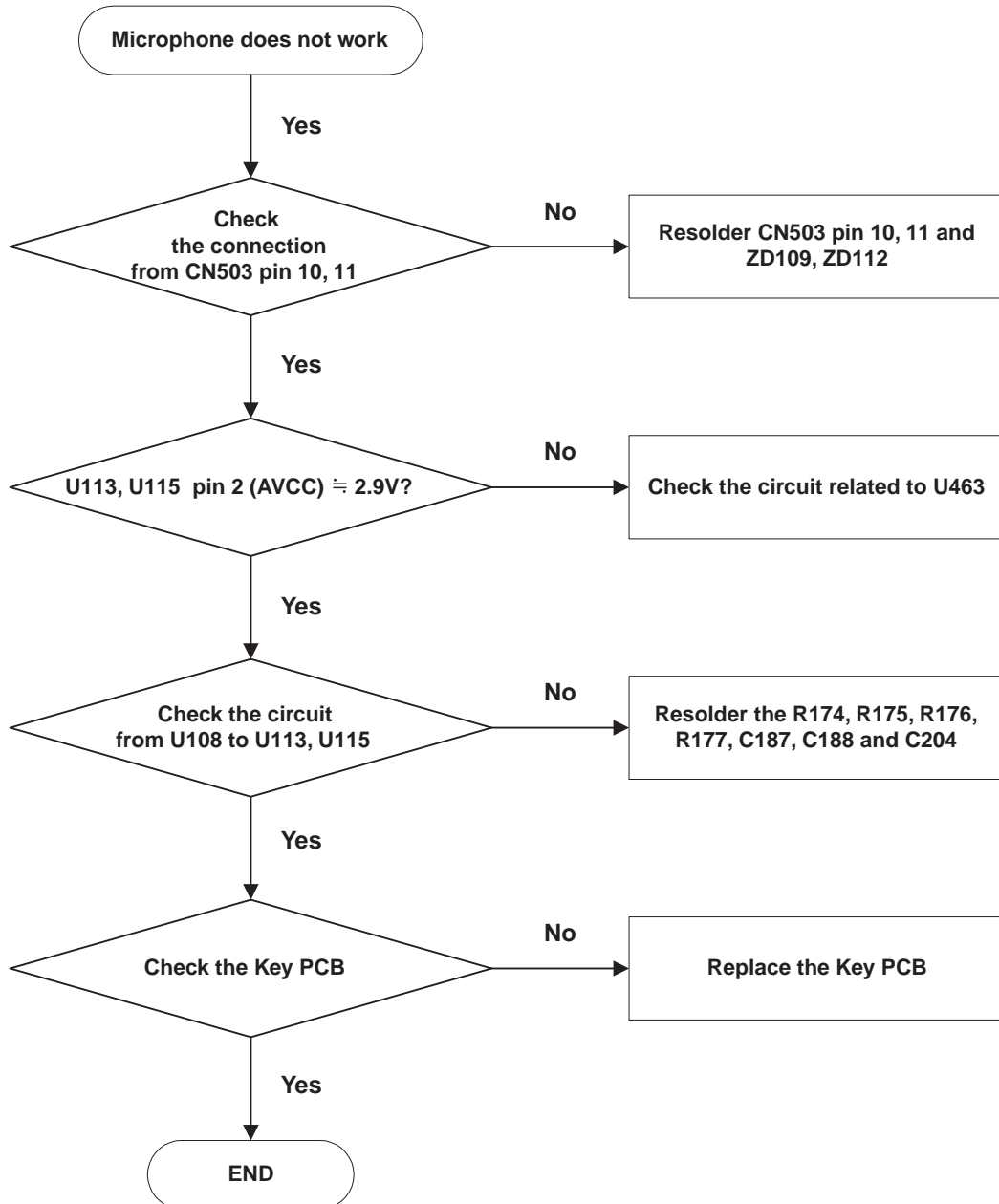

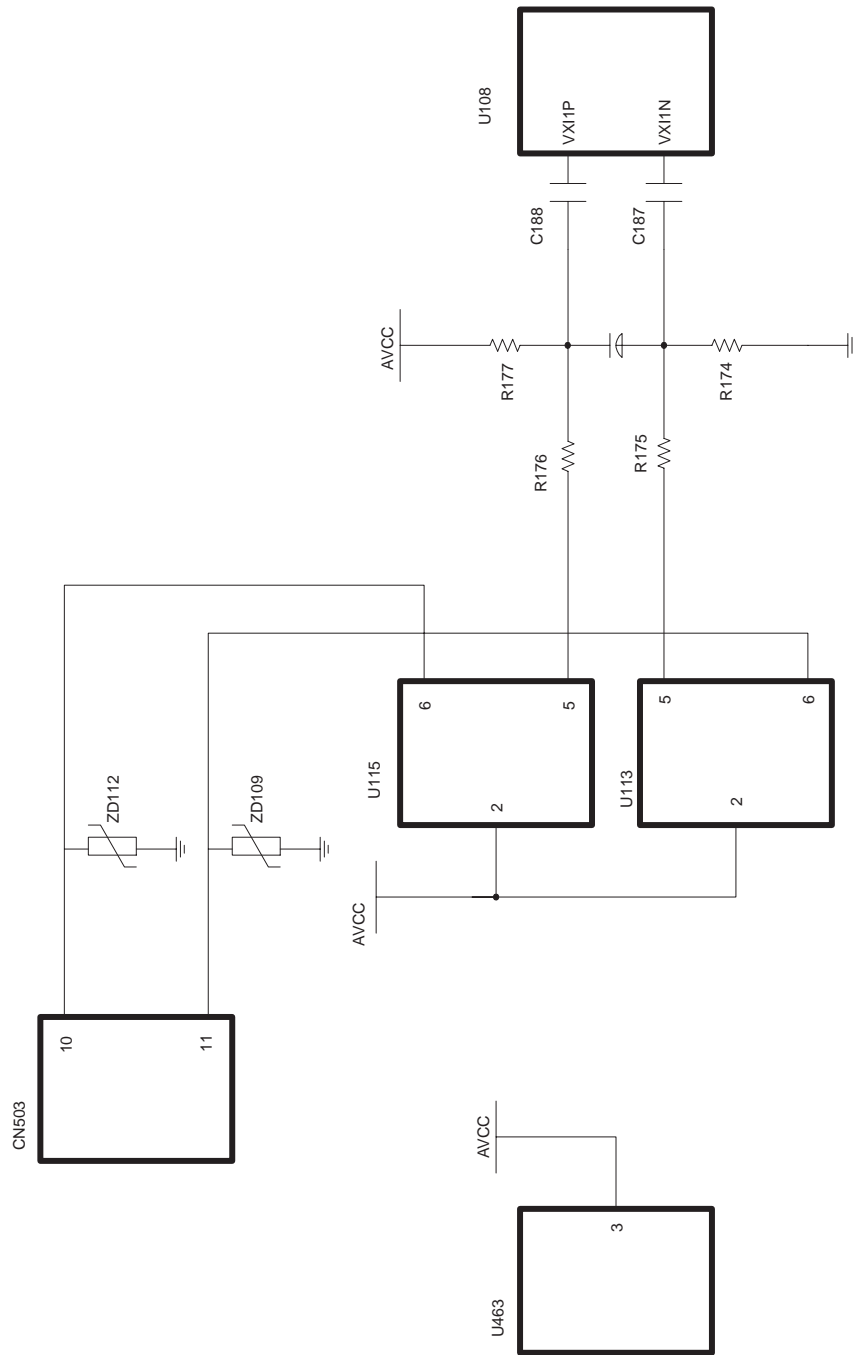

5-6 Speaker Part

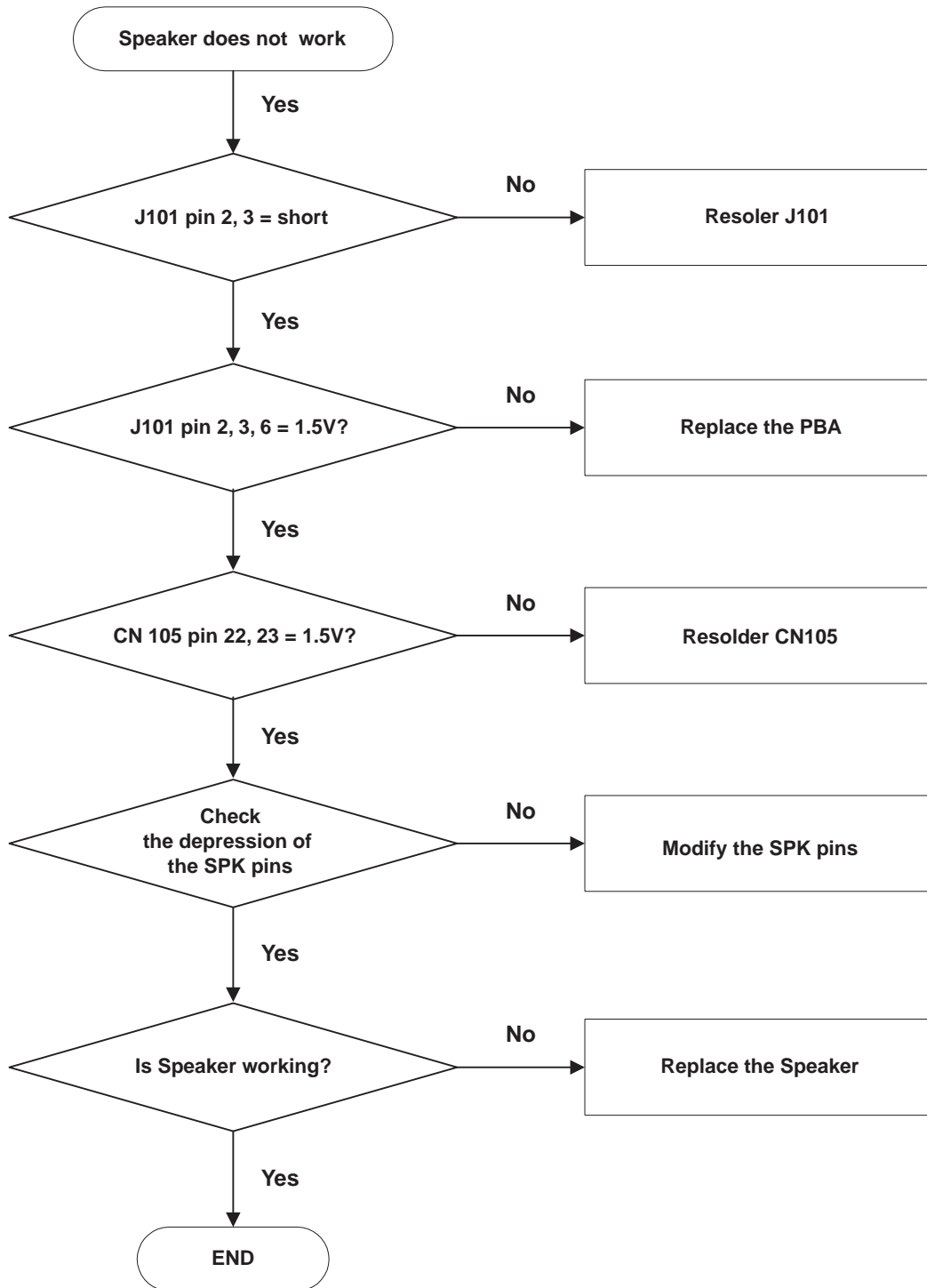

5-7 Key Data Input

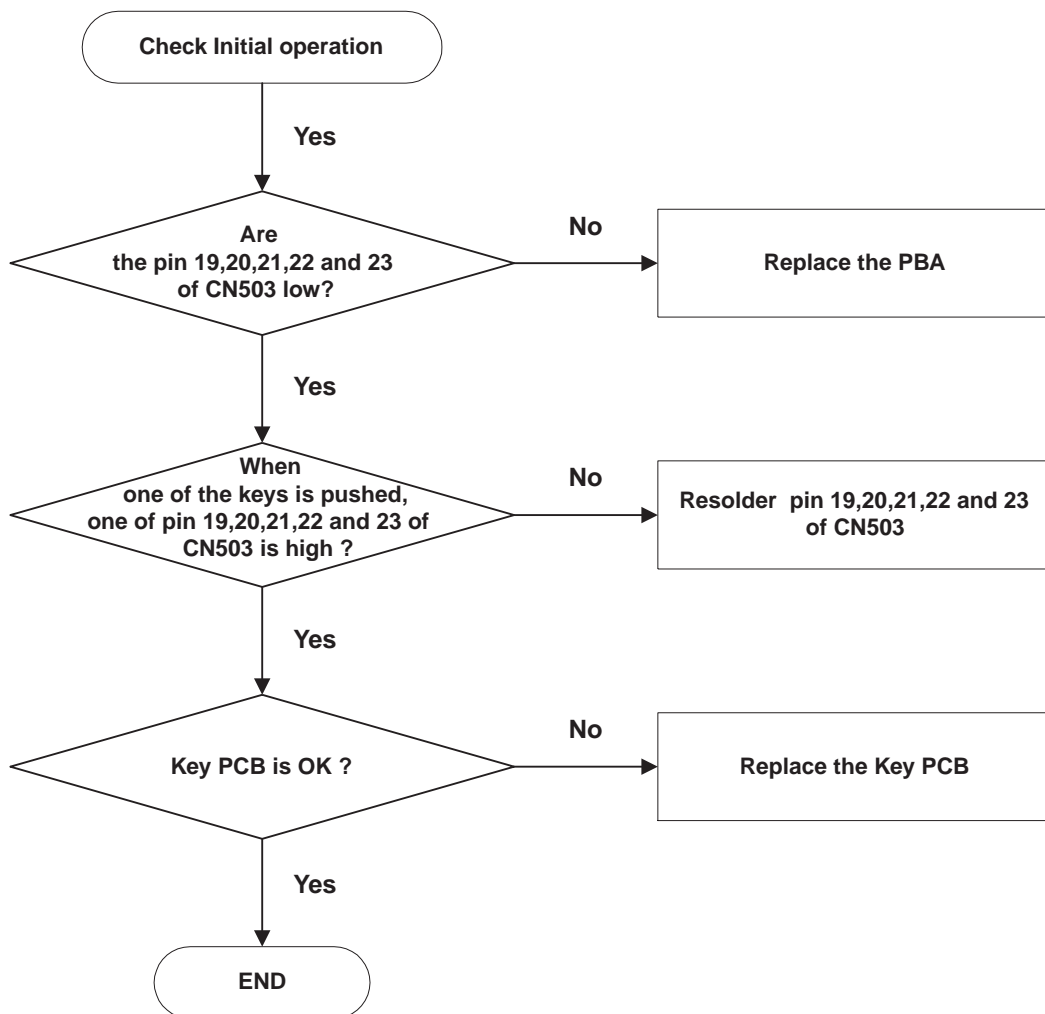

5-8 Alert Tone

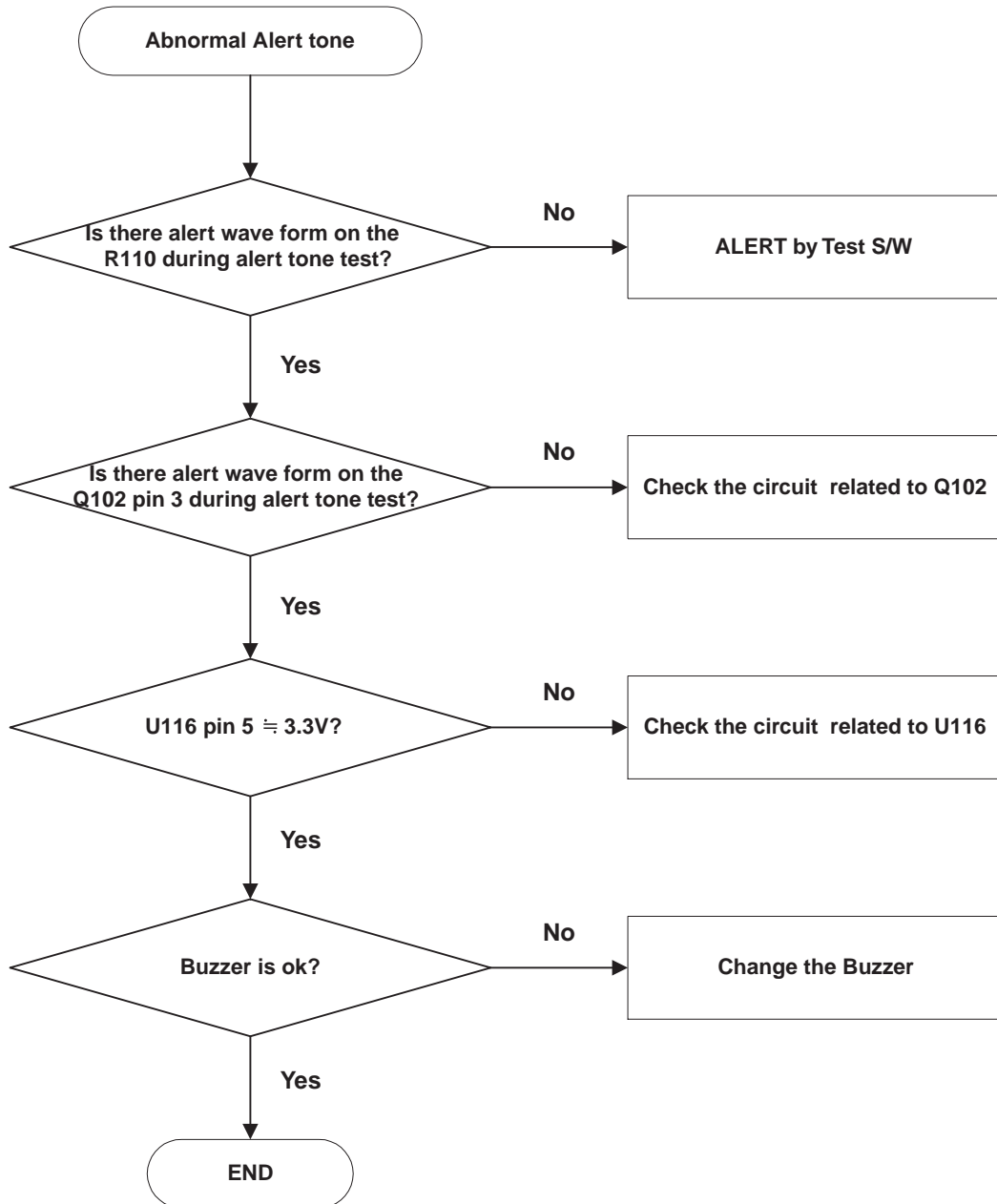

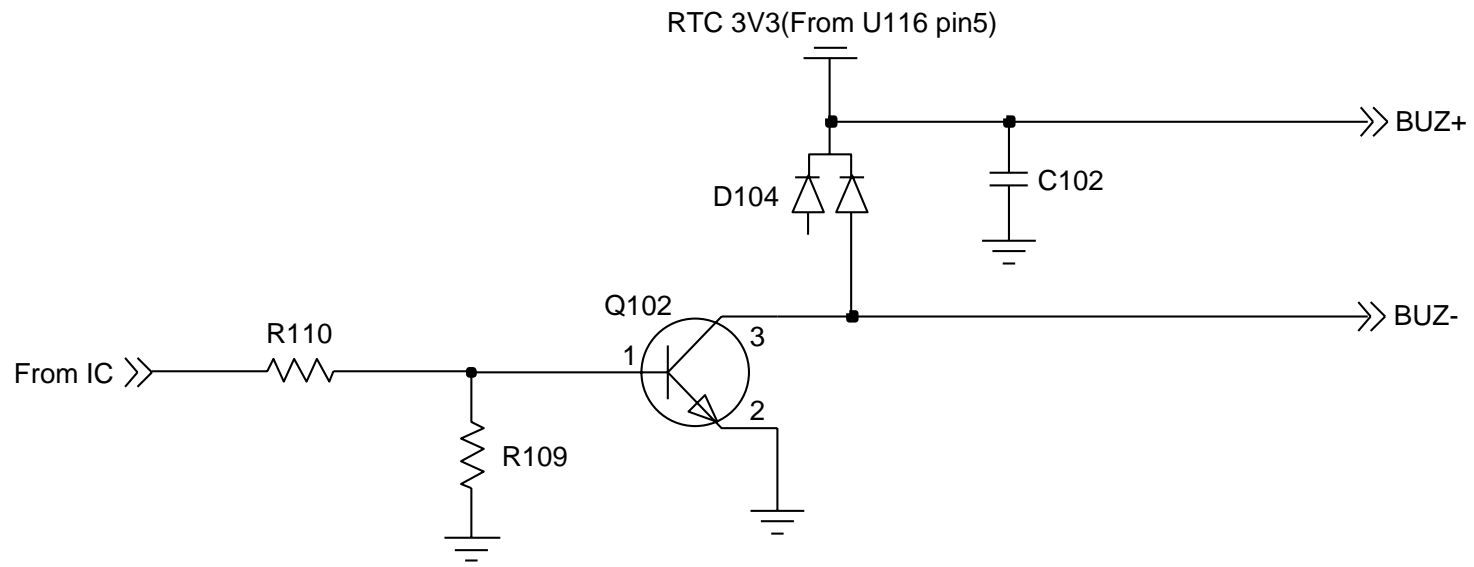

5-9 Ring Indicator

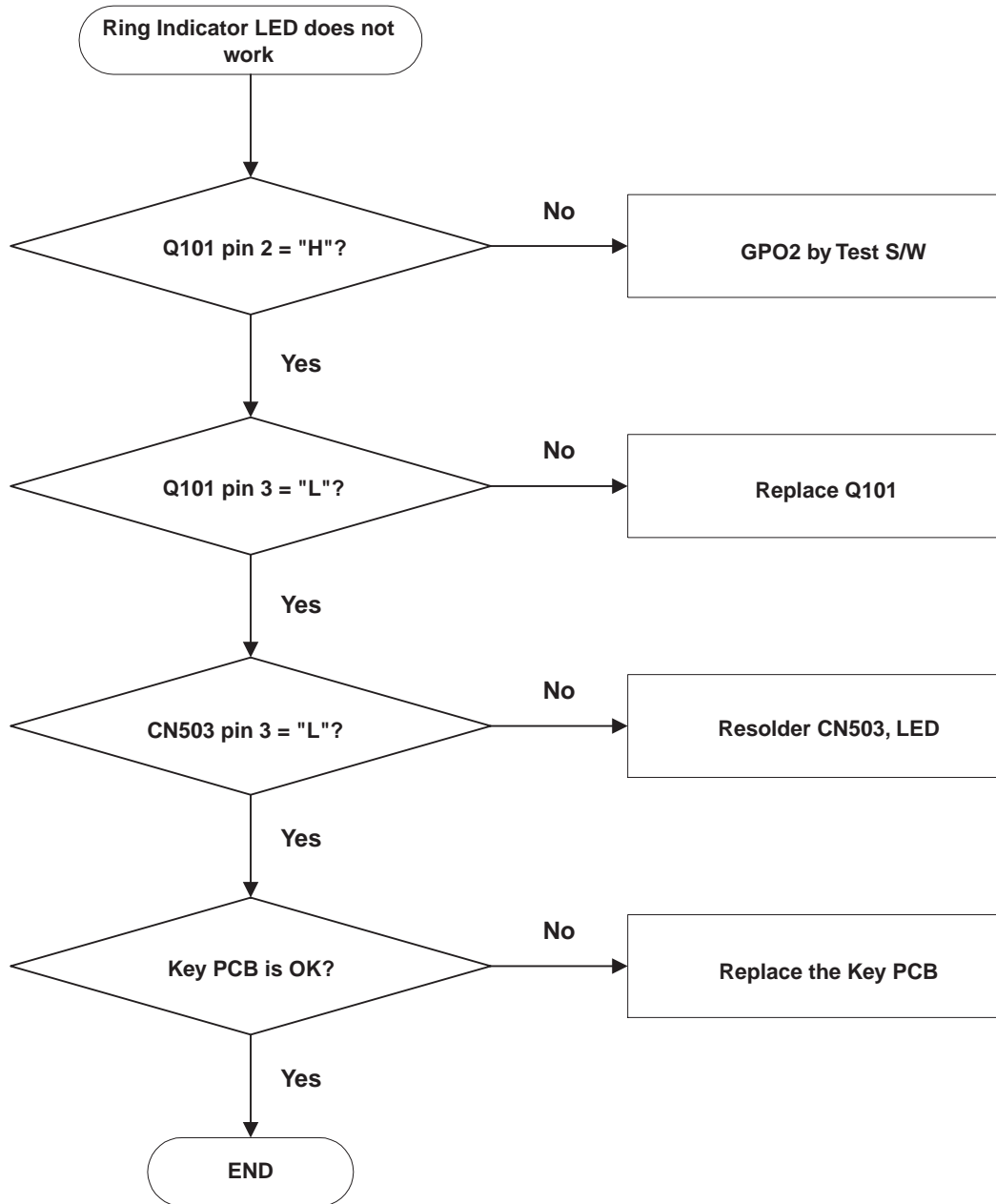

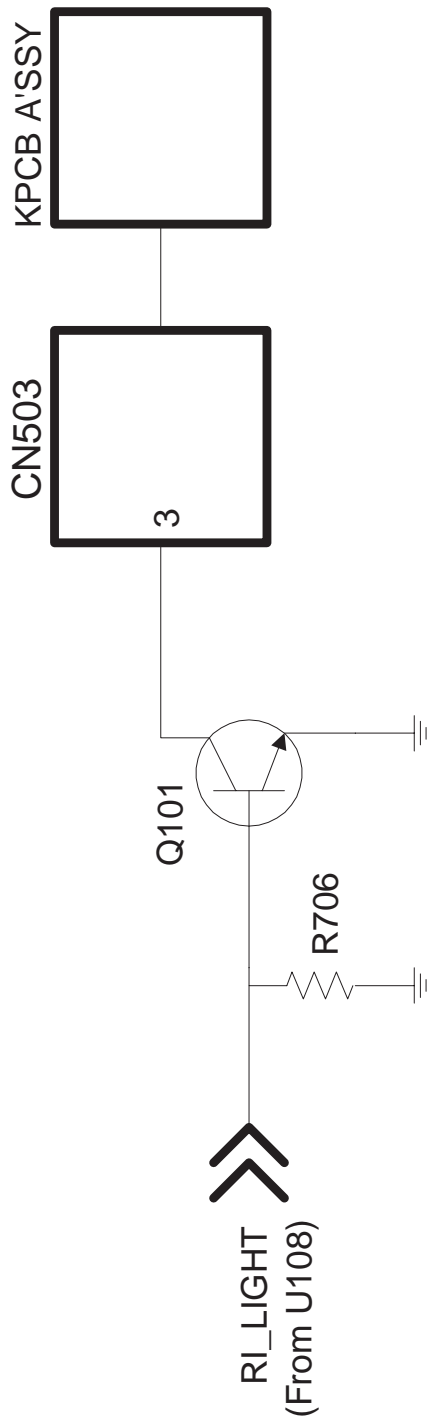

5-10 Back Light

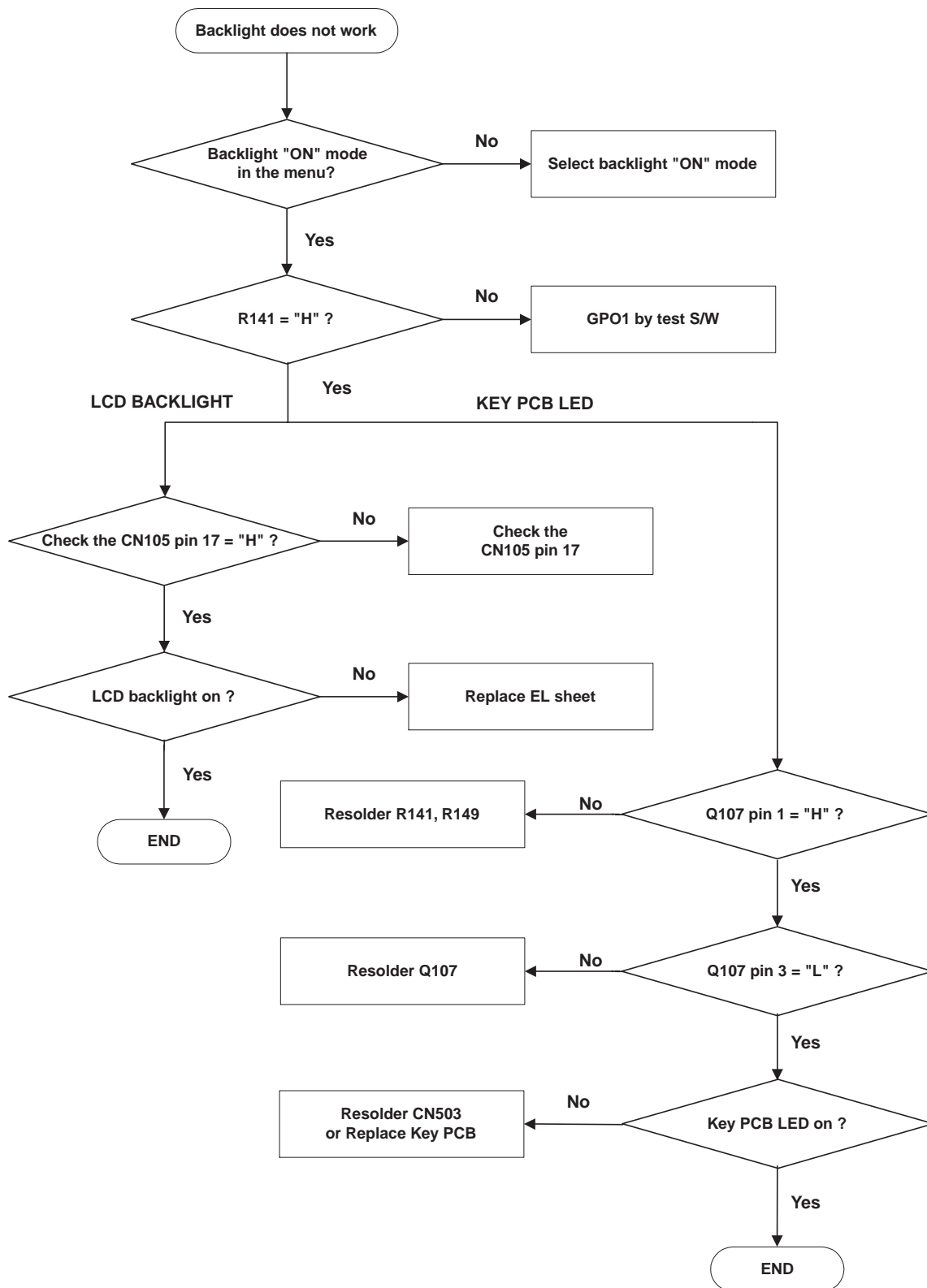

5-11 GSM Receiver

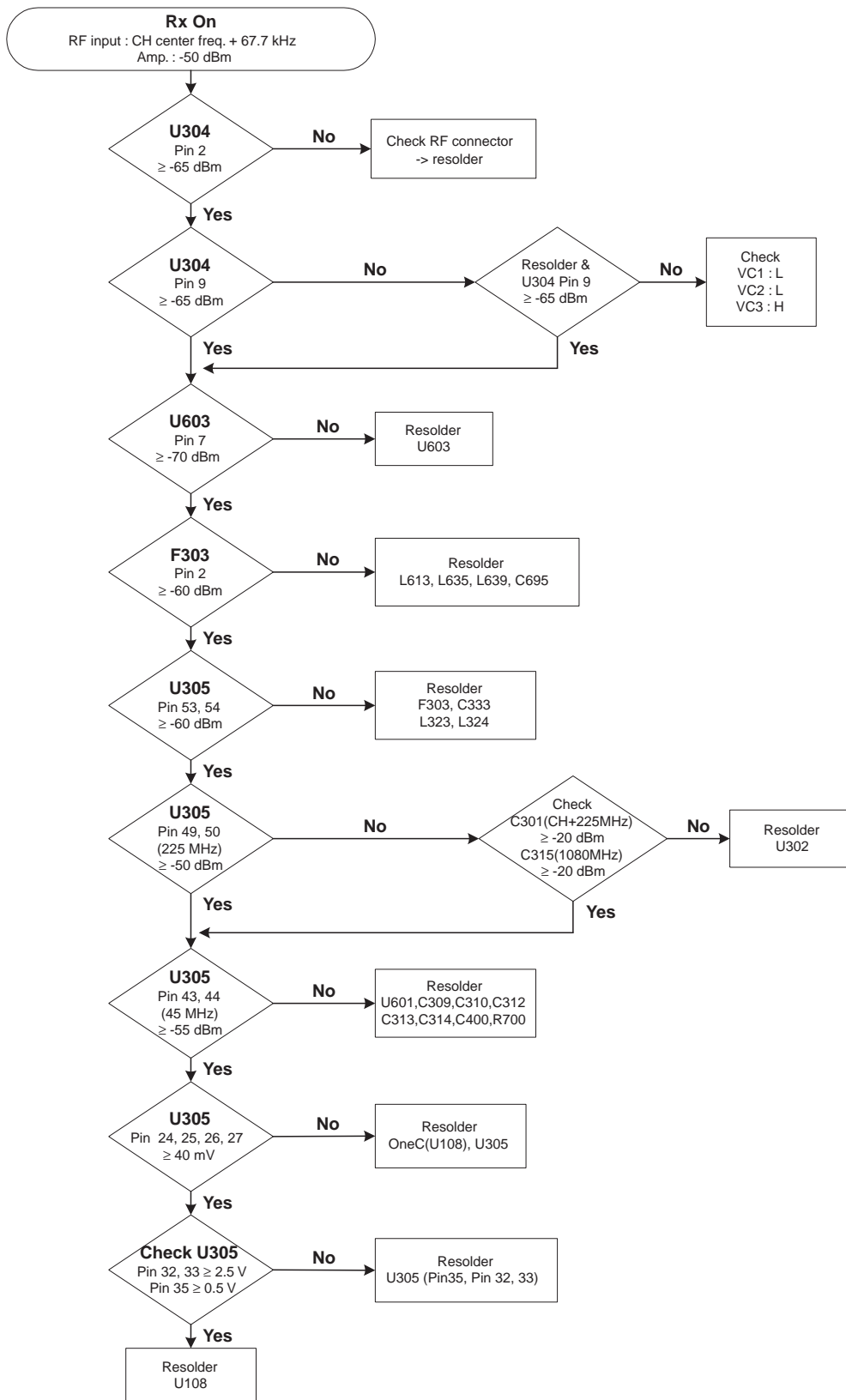

5-12 GSM Transmit

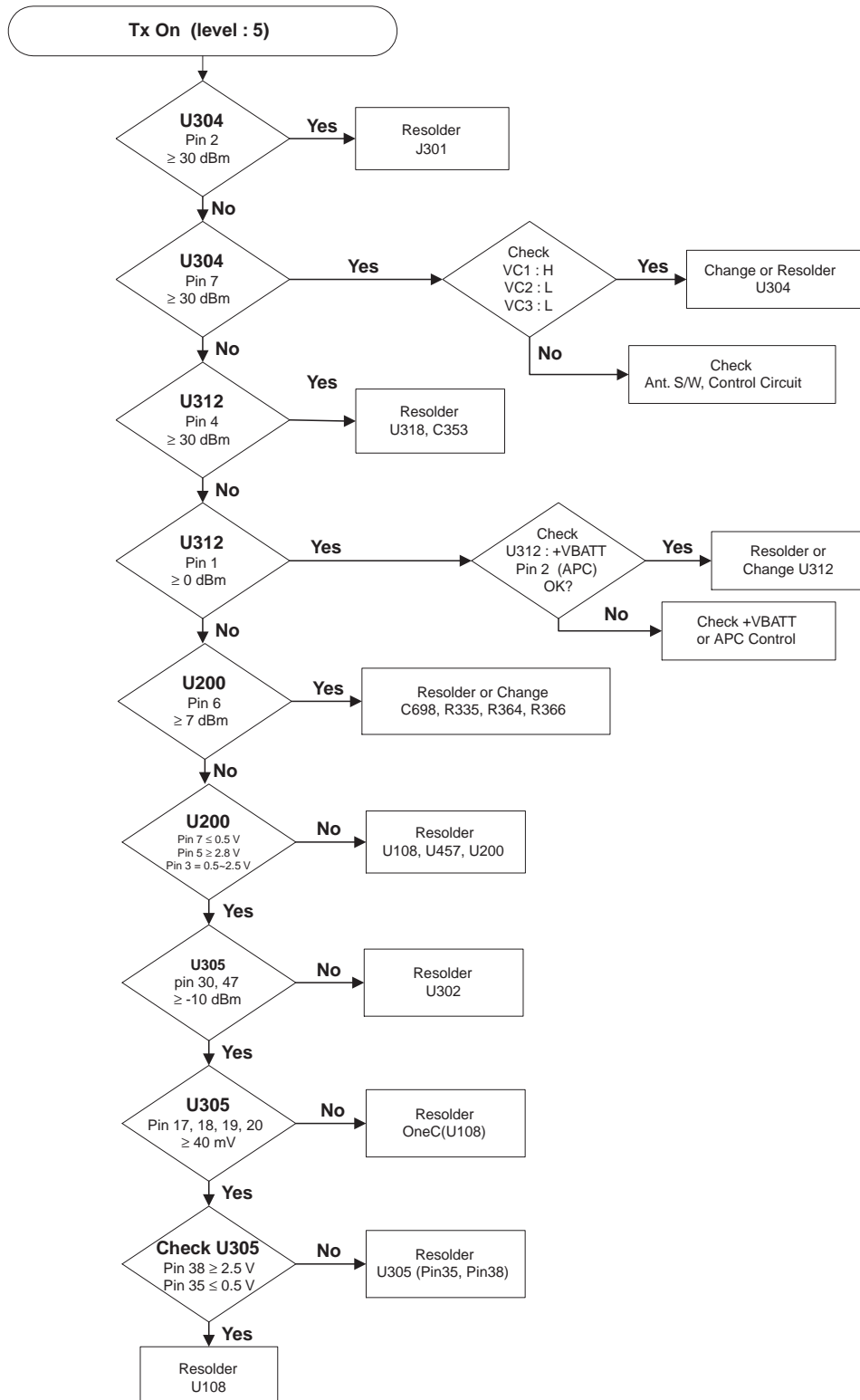

5-13 DCS Receiver

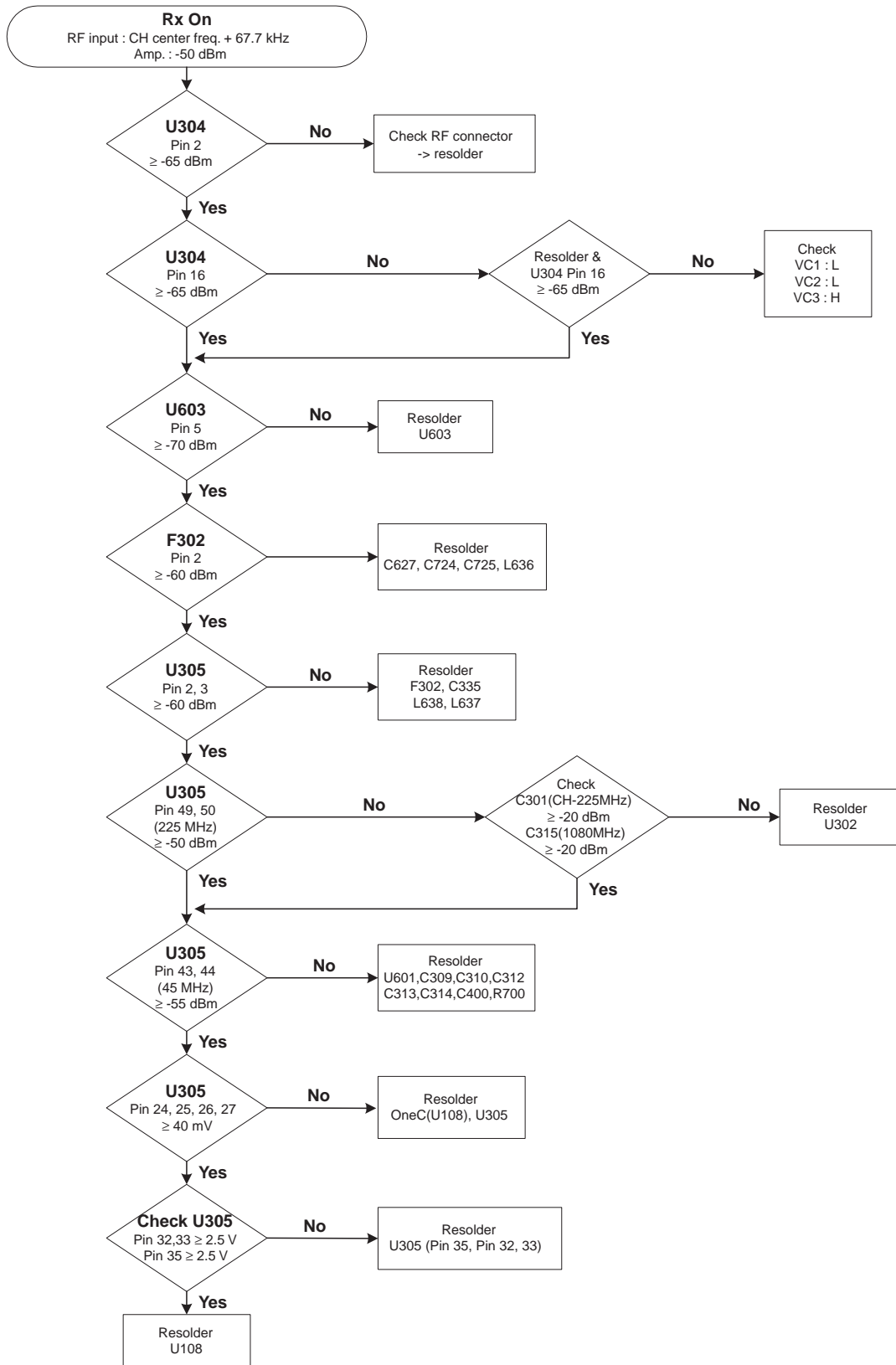

5-14 DCS Transmit

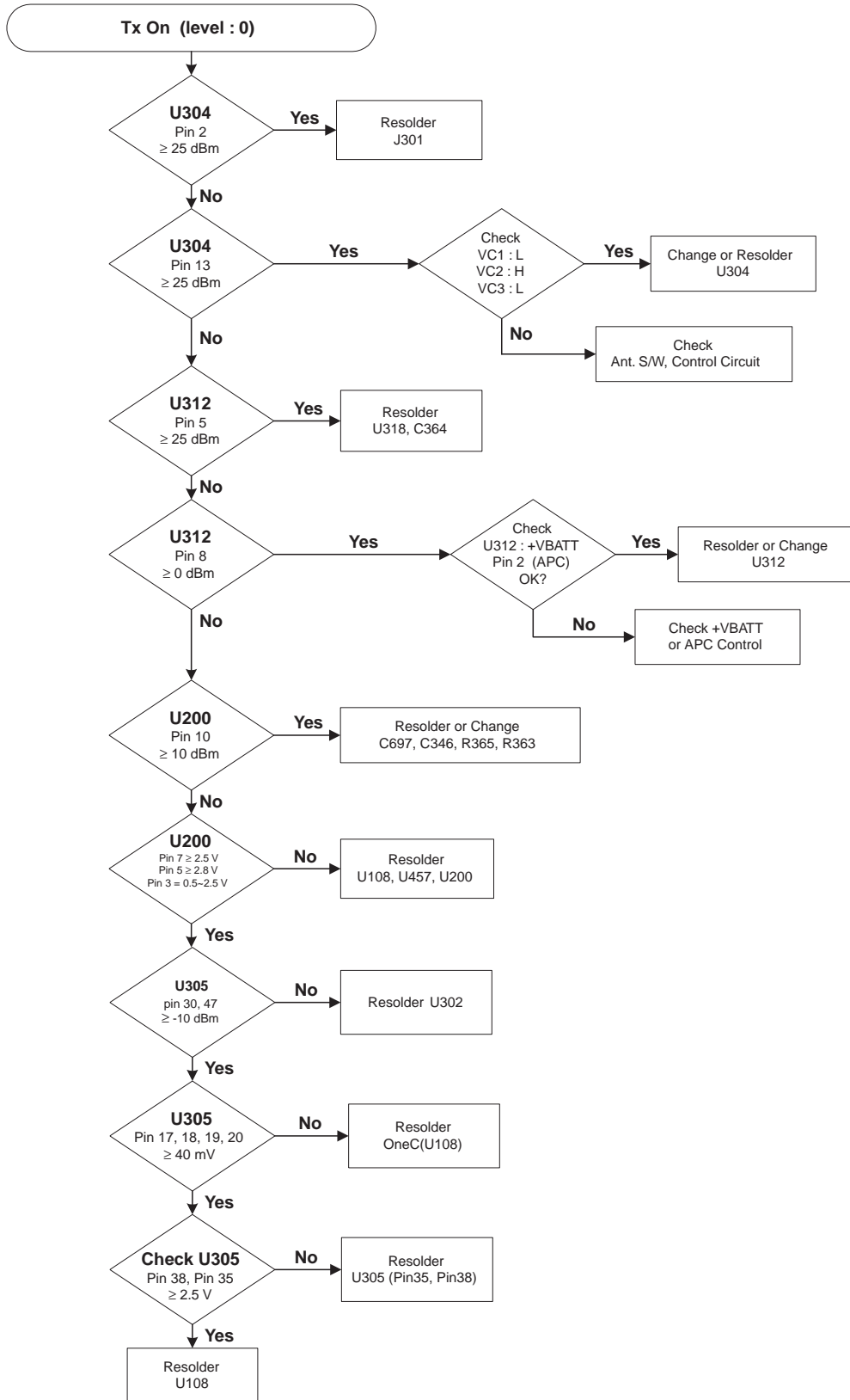

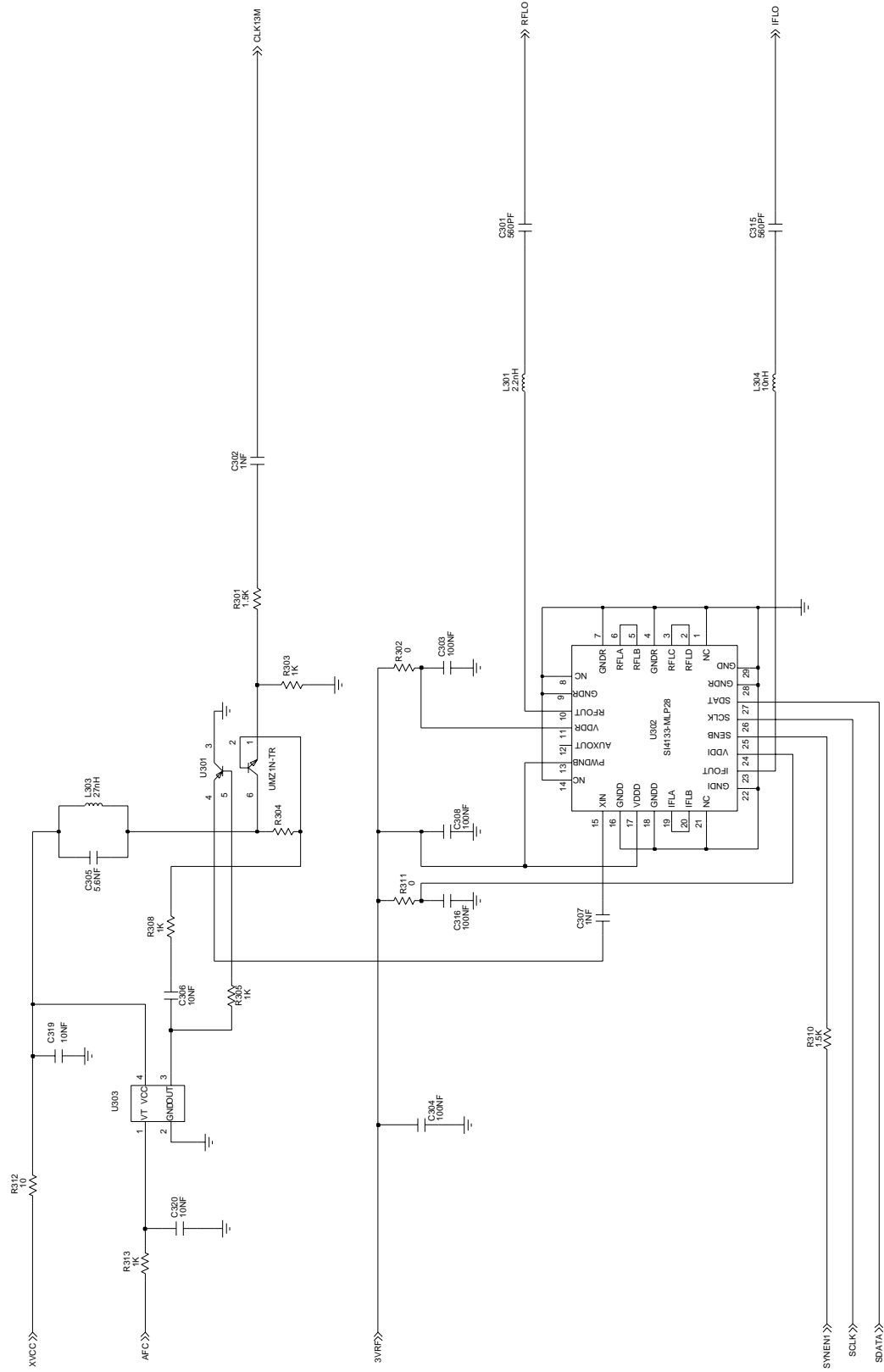

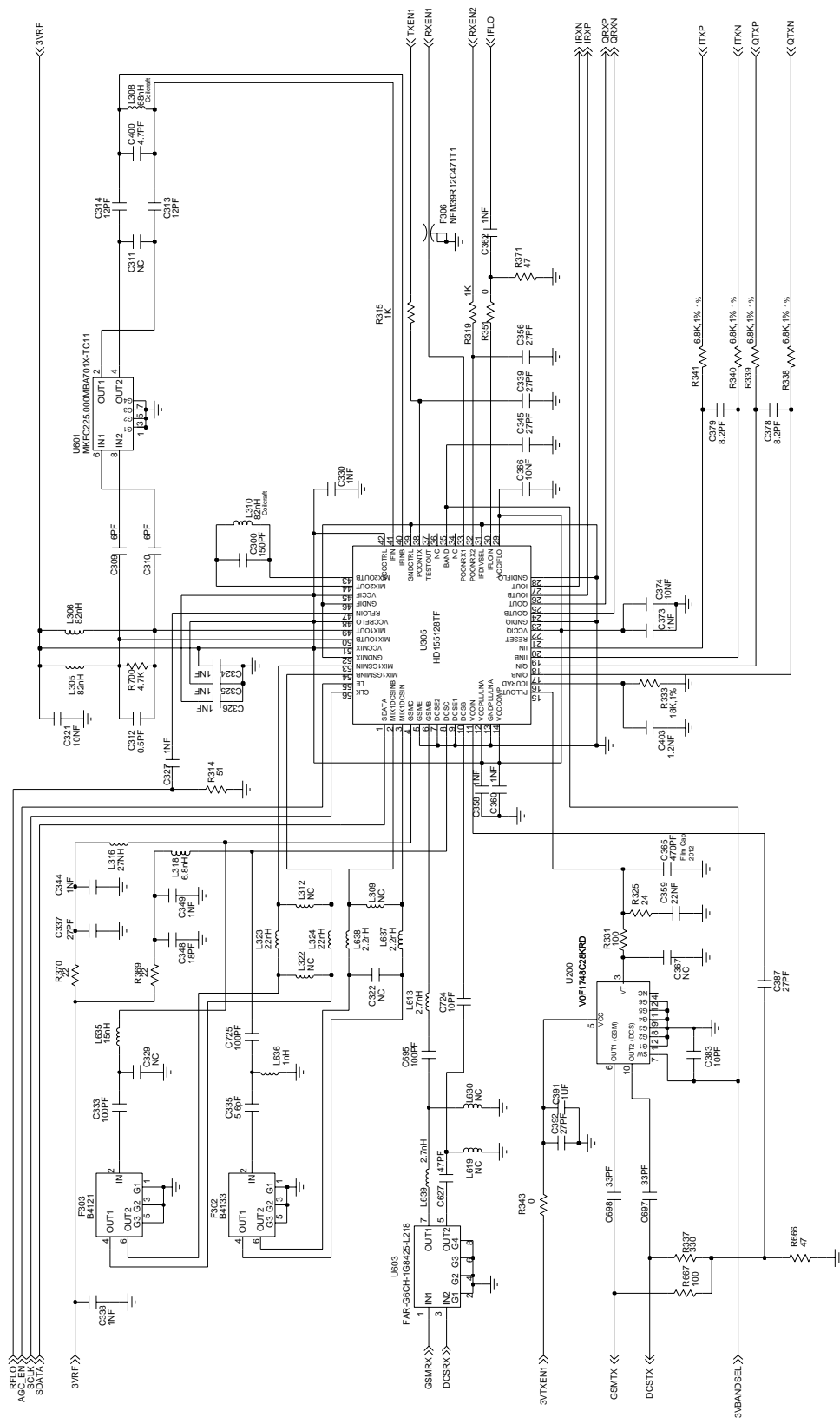

Flow chart of Troubleshooting and Circuit Diagram

